



Minifog EconAqua  
Water mist sprinkler systems

*Cool down.  
Fire Protection by*

**MINIMAX**

*The Minifog EconAqua system developed by Minimax uses innovative low-pressure water mist technology to offer a very efficient way of fire-fighting in office buildings and in hotels, in underground car parks, and in buildings with similar fire hazards. People, assets, and the environment are thus safely protected around the clock. Furthermore, the installation of a Minifog EconAqua system may help to meet legal requirements for instance those involved when applying for a building permit. Fire insurers have also recognized the effective fire protection provided by Minifog EconAqua and may grant premium discounts.*

Minifog EconAqua uses up to 85 % less water than a classic sprinkler system. This level of efficiency is otherwise only achieved with high-pressure water mist systems that typically work with pressures in the range of 40 to 120 bar. With Minifog EconAqua, a system pressure of 16 bar is sufficient. Due to the very low amount of water used, potential water damage is reduced to a minimum.

Moreover, the EconAqua pump room can generally be much smaller than a classic sprinkler pump room. This not only saves space but also construction costs as well. The use of pipes with much smaller diameters leads to substantial space savings along the pipe routes, particularly in suspended ceilings. Many existing buildings which could not be fitted with a fire suppression system due to a lack of space can now be retrofitted, thanks to Minifog EconAqua.

Minifog EconAqua water mist sprinkler systems can also be used without the need for costly trace heating when areas which are subject to frost are to be protected, such as car parks – Minifog EconAqua, unlike other water mist systems, enables dry pipe installations in the same way as with classic sprinkler systems. These are filled with compressed air or nitrogen instead of water during standby so as to avoid any frost damage.

Since Minifog EconAqua is a low-pressure system, it can be combined both with classic sprinkler and hydrant systems, and can therefore often use an existing water supply. It can also be connected to the fire brigade supply for additional backup, e.g. in the event of power failure to the pumps.

The outstanding suitability of Minifog EconAqua has been documented through extensive fire testing carried out under realistic conditions in mock-ups of original buildings. The Minifog EconAqua system is approved by the German VdS.

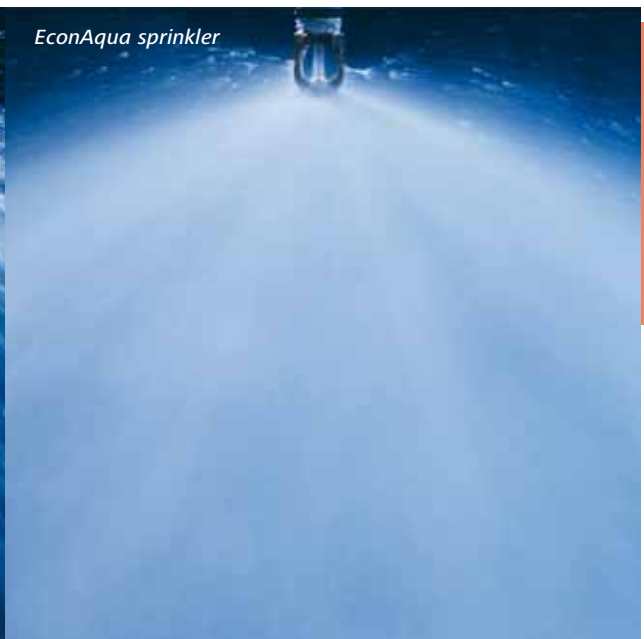

# HIGH PERFORMANCE

## with low water consumption

In the event of a fire, only the sprinklers located in the immediate vicinity of the fire are activated. Thus the fire is fought immediately while using a low volume of finely sprayed water. The surrounding sprinklers remain closed.

During the development of the EconAqua water mist sprinklers, the screening method was extensively used. The result is a range of special sprinklers which benefit from the physical advantages of a water mist spectrum at an operating pressure of as low as 5 bar.

EconAqua water mist sprinklers are sealed by a fast-response glass bulb (RTI < 50) and therefore react extremely quickly to heat from a fire. The operating temperature can be adapted to the local conditions. The protected area of the EconAqua water mist sprinklers is up to 16 m<sup>2</sup>, which is significantly larger than the typical coverage of classic sprinklers.



### The right water mist sprinkler for every occasion

- ▶ **Standard water mist sprinklers EconAqua**  
EconAqua standard sprinklers type "P" (pendant) and "U" (upright) are fitted to the ceiling. The sprinklers are available as standard in brass, chrome-plated, and stainless steel.
- ▶ **Horizontal water mist sprinklers EconAqua**  
EconAqua sprinklers type "WWH" are installed horizontally into the wall, especially in rooms where sprinkler pipes cannot be laid along the ceiling. The sprinklers are chrome-plated as standard.
- ▶ **Undercover water mist sprinklers EconAqua**  
EconAqua Undercover sprinklers type "CCP" or "RP" integrate fire protection harmoniously and virtually invisibly into the ceiling. The "CCP" (concealed) design is available as standard with a chrome or white fine mesh cover. The "RP" (recessed) design has no cover.
- ▶ **Preaction water mist sprinklers EconAqua**  
EconAqua Preaction sprinklers type "DS21" are used in areas where accidental activation would cause unacceptable damage, e.g. in server rooms. The Preaction sprinkler is fitted with two release elements. Water is released only when both elements are triggered.
- ▶ **Dry water mist sprinklers EconAqua**  
Pendant EconAqua dry sprinklers type "DP" are used when pipework is to be installed in an area subject to frost hazard and where upright sprinklers cannot be installed.

# DESIGN AND

## Safety at its best

In its design and function, the Minifog EconAqua system is similar to a classic sprinkler system. The system may be subdivided into one or more sections, the corresponding section valve sets, and the EconAqua pump room.

### Sections

Pipework with EconAqua water mist sprinklers run through the rooms to be protected. The nominal pipe diameters used in these areas mainly lie between DN20 and DN40 and are much smaller than those used in classic sprinkler pipework. In standby conditions the pipework in the sections is filled with pressurized water (wet system for frost-proof rooms) or with compressed air or nitrogen (dry system for rooms subject to frost hazard). In the event of a fire, the water mist sprinklers located in the immediate vicinity of the fire activate.

### Section valve sets

Every section is allocated an EconAqua valve set. In the event of a fire, i.e. after a sprinkler release, the pressure in the pipework of the affected section drops to a level such that the associated valve set is tripped and the fire-fighting process is started. At the same time a signal is sent to the fire detection control panel, in order to transmit an alarm and to better localize the fire.

### Wet pipe system for frost-protected rooms

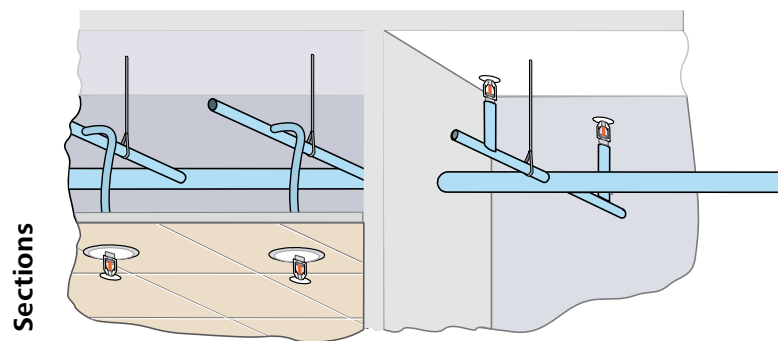

### EconAqua section valve sets

EconAqua section valve set wet



### Water mist systems

Since 1993, Minimax has developed and installed high-pressure and low-pressure water mist systems under the "Minifog" brand name for a wide range of applications, thus making it one of the pioneers of water mist technology. This technology utilizes the physical properties of the water more efficiently than classic water fire suppression systems. The water is emitted through special nozzles and sprinklers as a very fine spray under increased operating pressures. The result is a larger total surface of the water, allowing it to absorb heat and to evaporate more quickly. The cooling and smothering effect allows for particularly effective fire-fighting using a minimum amount of water.

### EconAqua pump room

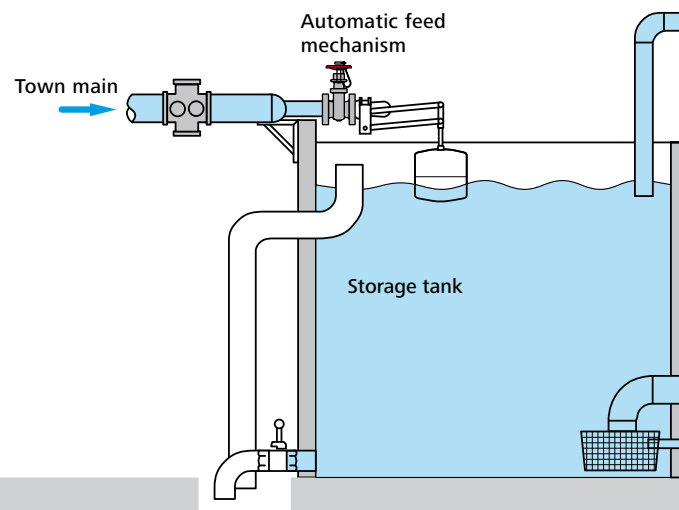

# FUNCTION

## EconAqua pump room

In addition to the units which maintain the pressure in the pipework of the sections, the EconAqua pump room also includes the fire detection panel, the central alarm station, the master pump, a water source, and various other components that ensure safe operation of the fire-fighting system.

The much smaller amount of water used in the Minifog EconAqua system means that the EconAqua pump room is up to 80% smaller than a classic sprinkler pump room.

The signals of the section valve sets and of the central alarm valve are transmitted to the fire detection panel. From here, alarms are set off to alert internal and external rescue teams. The main pump automatically starts if the pressure in the main distribution piping drops as a result of one of the section valve sets opening. The source of water may either be a water tank with automatic feed or – when using suitable safety devices – a direct connection to the public drinking water system.

## Dry pipe system for rooms subject to frost hazard

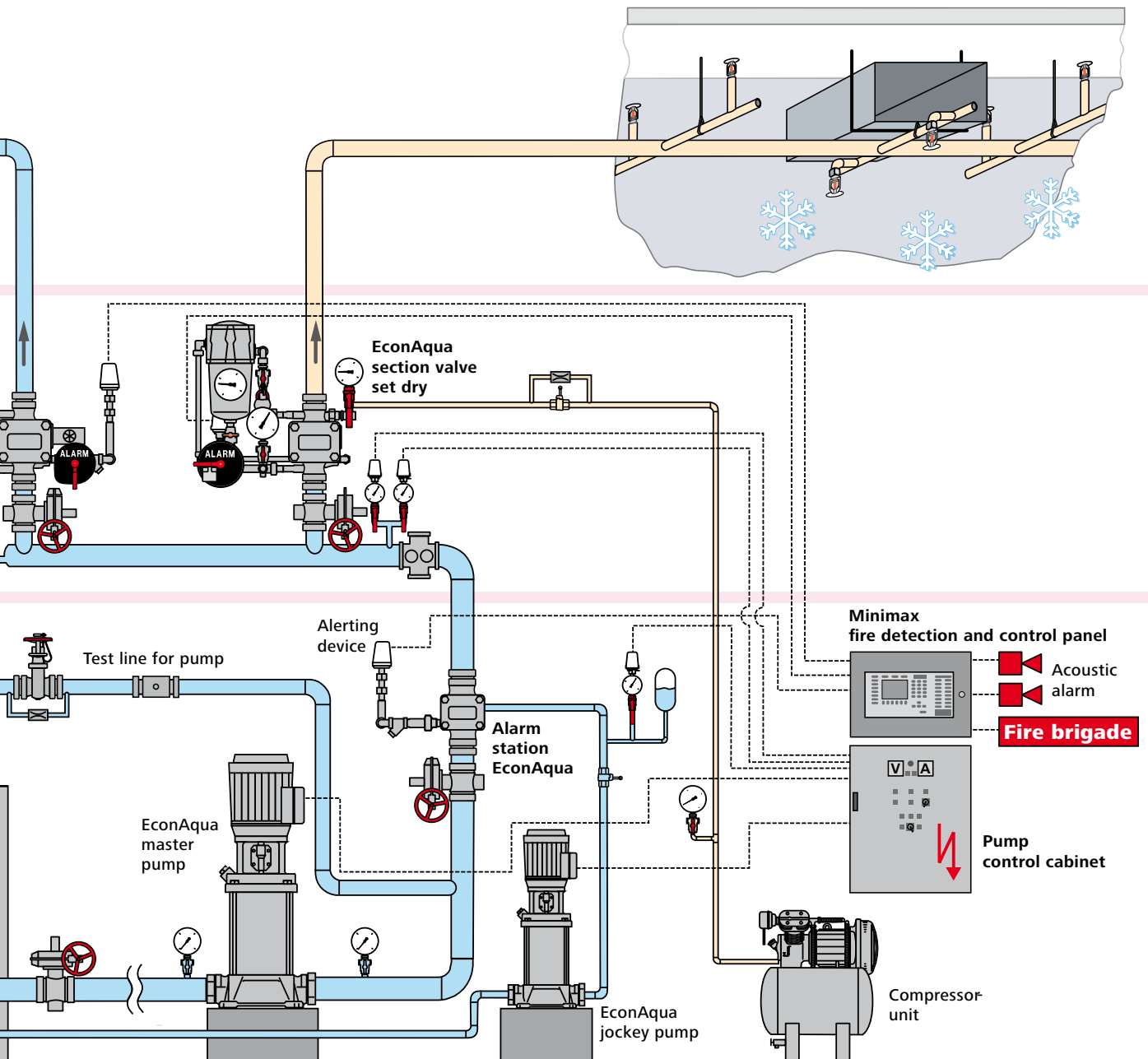



# APPLICATION

## A class of its own



The range of applications for which the Minifog EconAqua water mist sprinkler systems can be used covers several fire hazard classes as defined in the VdS guidelines for sprinkler systems (VdS CEA 4001). These include fire hazard classes LH, OH1 (except production hazards), and OH2 (only surface and underground car parks).

### Typical applications

- ▶ Government buildings
- ▶ Railway stations
- ▶ Banks
- ▶ Libraries
- ▶ Office and administration buildings
- ▶ Hotels
- ▶ Churches
- ▶ Hospitals, senior citizen's homes, and other care facilities
- ▶ Multi-story car parks
- ▶ Restaurants
- ▶ Schools, universities, and other educational establishments
- ▶ Penal institutions and approved schools
- ▶ Underground car parks
- ▶ Hostels and apartment houses



# OPTIMAL

## Minifog EconAqua – the optimal solution

Wherever a Minifog EconAqua water mist sprinkler system can be used, it is generally the best solution, since Minifog EconAqua combines the advantages of a sprinkler system with those of a high-pressure water mist system. One important criterion to be considered in evaluating the alter-

native solutions for a certain application is the total cost of the equipment. Besides the direct costs for the installation of the system this also includes the cost of constructing the pump room, costs for the water and electricity supply, and the maintenance costs.

### Example: Minifog EconAqua saves on construction costs

The use of Minifog EconAqua can lead to a pump room which is around 12.5 m<sup>2</sup> smaller than the one for a classic sprinkler system. Based on average building costs of € 1,930/m<sup>2</sup> of gross building surface area, the reduced space requirements alone lead to construction cost savings of more than € 24,000.

*\*Source: German BKI 2012, relating to hospitals in Germany*

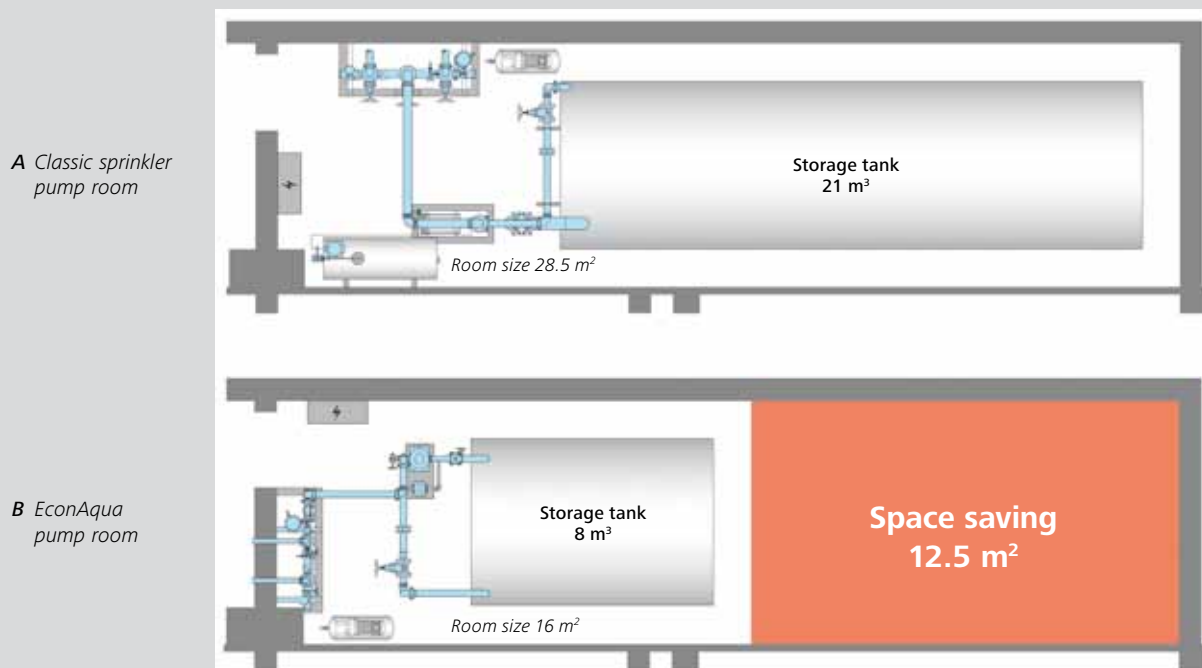

E|con|A|qua fire suppression system [e`kon:akva:...],  
(Technology)

Low-pressure water mist system based on sprinkler technology with a particularly low consumption of water, thus providing great benefits for building owners and operators

# ADVANTAGES

at a glance

## Advantages of Minifog EconAqua compared to classic sprinkler systems

- ▶ Up to 85% less water used – water damage is hereby reduced to a minimum.
- ▶ Substantial space savings along the pipe routes, particularly in suspended ceilings, thanks to the smaller pipe diameters.
- ▶ Significantly lower space requirement for water supply, since EconAqua pump rooms can be much smaller than classic sprinkler pump rooms.
- ▶ EconAqua water mist sprinklers can generally offer significantly greater coverage than classic sprinklers.
- ▶ Lower one-off and recurring costs for connection to the water and electricity supply owing to reduced water consumption and pump power demand.
- ▶ Ideal for retrofits in existing buildings.

## Advantages of Minifog EconAqua compared to high-pressure water mist systems

- ▶ Significantly lower costs for installing the equipment by using low-pressure components.
- ▶ Minifog EconAqua systems allow use of galvanized pipes, plastic pipes, or pipes cast into concrete.
- ▶ Minifog EconAqua can be combined with both classic sprinkler and hydrant systems.
- ▶ Minifog EconAqua can be fed by a fire brigade supply – an additional backup, e.g. in the event of power failure.
- ▶ Lower one-off and recurring costs for connection to the electricity supply owing to reduced pump power demand.
- ▶ Minifog EconAqua systems can also be used as dry pipe systems without trace heating in areas subject to frost hazard.

Minimax GmbH & Co. KG  
Industriestraße 10/12  
D-23840 Bad Oldesloe  
Phone: +49 (0) 45 31 8 03-0  
Fax: +49 (0) 45 31 8 03-248  
E-Mail: [water@minimax.de](mailto:water@minimax.de)  
[www.minimax.de](http://www.minimax.de)



Technical alterations reserved.