

INTEGRATED DELUGE SKID

MODEL DPACK



Technical Data

MODELS DPACK-AD, DPACK-AW

NOMINAL SIZE 200NB, 150NB, 100NB, 80NB, 50NB

MAX. SERVICE PRESSURE 12 Bar (DSK-AD & DSK-AW)

TRIM Galvanized steel with brass valves

APPROVAL UL Listed

FINISH RAL 3000 painted

ORDERING INFORMATION Size, Trim Type

GENERAL DESCRIPTION

Integrated Deluge Skid model DPACK is pre-assembled Deluge system package built around UL listed "HD" make Deluge Valve Model A. Deluge valve skid comes in three different types of actuations – 1. Pneumatic release, 2. Hydraulic release 3. Electric release. Deluge Valve is known as a system control valve in a deluge system, used for fast application of water in a spray system. Deluge valve protects areas such as power transformer installation, storage tank, conveyor protection and other industrial application etc. With the addition of foaming agent it can be used to protect aircraft hangar and inflammable liquid fire.

DPACK is enclosed from all sides with removable panels with front side open or with an option of hinged doors with lock for front side. Glass openings are provided on the doors for viewing the pressure gauges. The entire package is pre wired and connections are flanged to provide minimal installation time. The package includes inlet, outlet and bypass valves, pressure switches, solenoid valves, inlet and outlet connections, common drain connection and junction box for electrical connection. Pressure switches are provided on the outlet of the deluge valve to indicate the actuation of the valve. In addition another pressure switch is provided in pneumatic line for indication of low pressure or fire condition with pneumatic release trims. The DPACK panels are of galvanized steel of minimum 16 SWG. The panels and the skid frame are painted with Red RAL 3000 paint. The skid is provided with corrosion resistant stainless steel

nameplate. Stainless steel name plates are provided for valves for easy identification.

INSTALLATION

1. Place the skid at the desired location on the proper foundation and secure it with the anchoring bolts.
2. Connect the water inlet and system piping.
3. Connect the common drain connection to an open drain.
4. Do not restrict or reduce the drain piping.
5. Connect the detection network piping
6. Complete the field wiring of junction box.
7. Refer to Deluge valve catalogue model A for valve commissioning, installation and troubleshooting instructions.

Note: Support the external piping firmly to prevent strain and stresses on the piping of the skid/cabinet and its components.

ADVANTAGES

- Professionally pre-assembled and factory tested
- Aesthetically pleasing appearance
- Provided with optional cabinet lock
- All gauges externally visible through transparent polycarbonate window
- All side panels easily removable for ease of maintenance
- 14 SWG cabinet red powder coated
- Pressure switch, solenoid valve mounted, pre-wired & terminated into junction box
- UL Listed modular package
- Quick and convenient installation
- Can be custom designed and manufactured
- Cost effective and reduced installation time

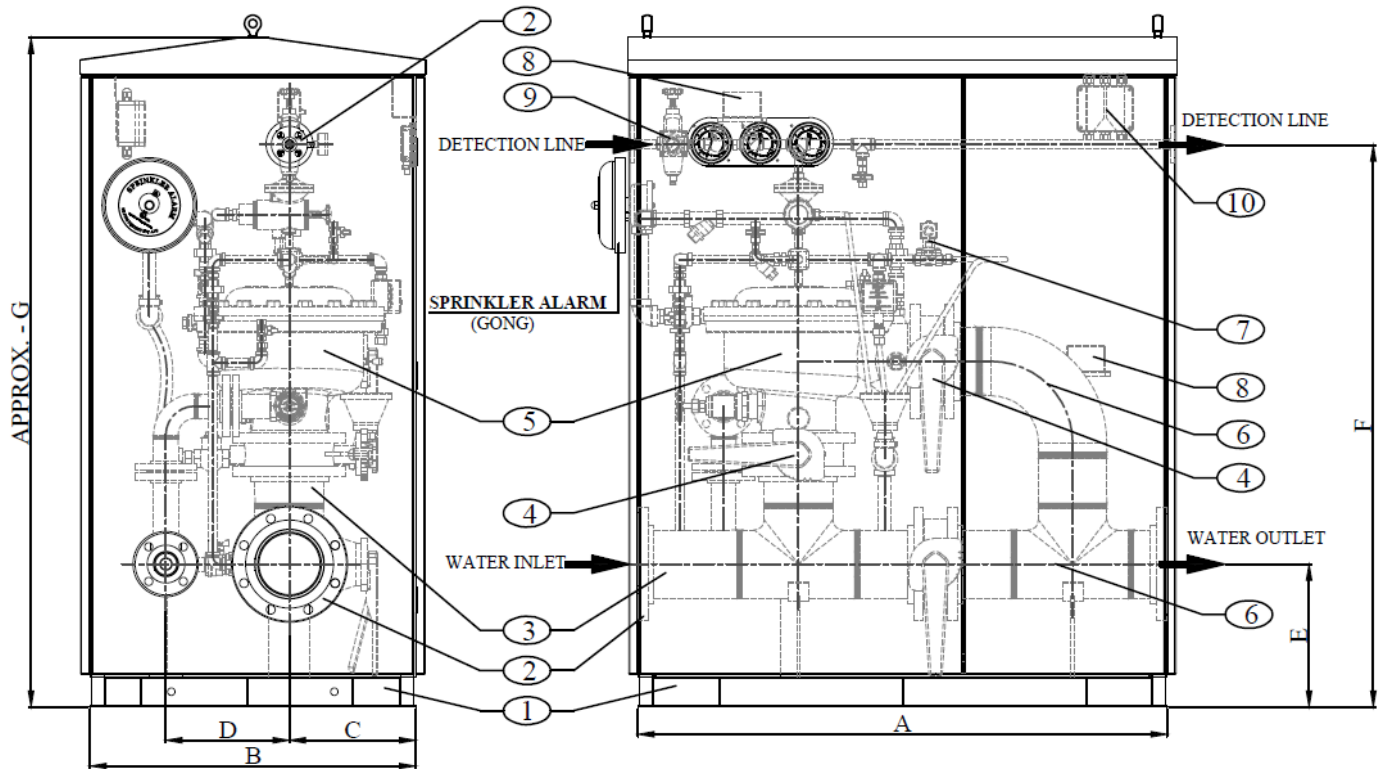
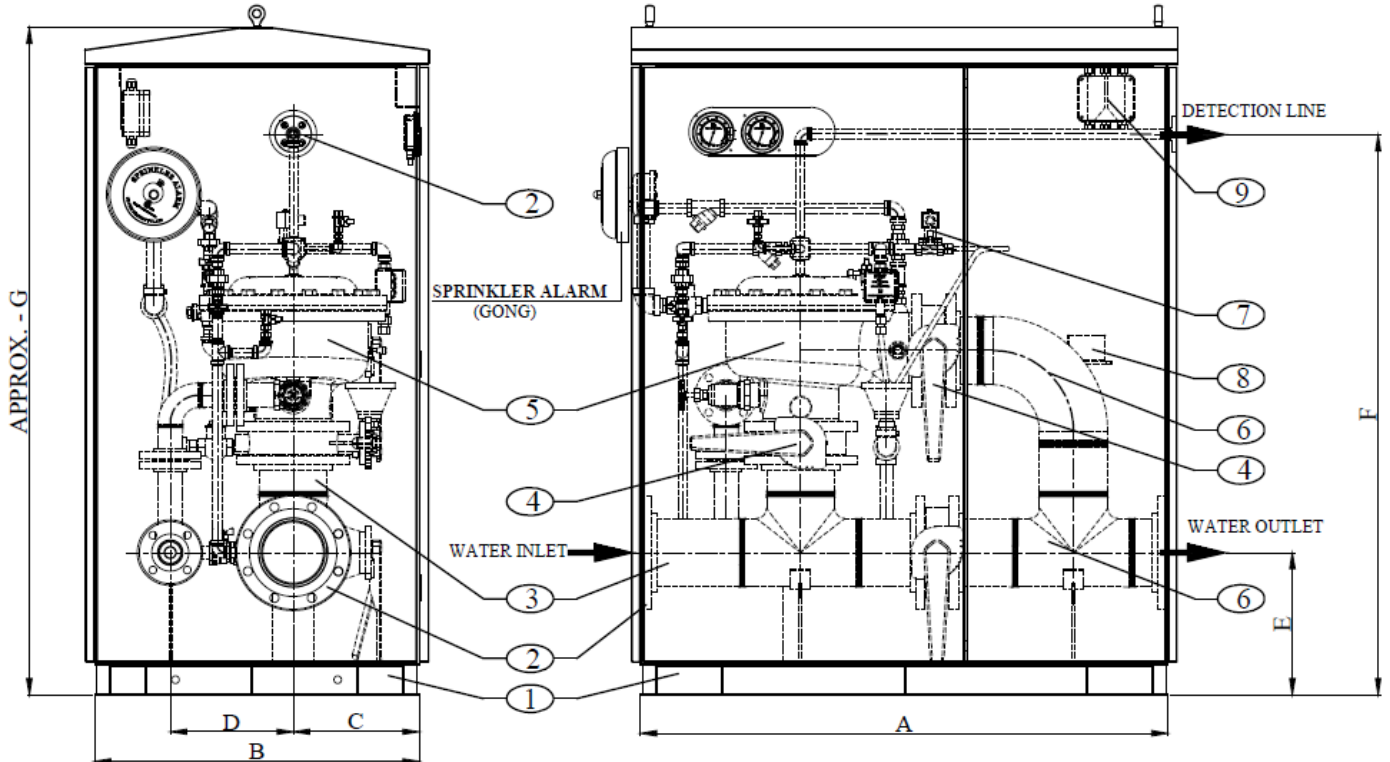

DELUGE VALVE SKID MODEL DPACK-AD

DELUGE VALVE SKID MODEL DPACK-AW

Part List

- | | |
|--|--|
| <ol style="list-style-type: none"> 1. Base frames with panels (carbon steel) 2. Flanges (ASTM A105 ANSI B16.5 RF#150) 3. Pipes (ASTM A-106/A-53 Schedule 40) 4. Butterfly Valves liver operated (Cast Iron) 5. Deluge Valve A with Wet/Dry Pilot trim | <ol style="list-style-type: none"> 6. ButtWelded fittings (ASTM A234 GR. WPB) 7. Solenoid Valve 2-way (Parker/Rotex Make) 8. Pressure Switch (DAG/POTTER Make) 9. Junction Box (Weather proof) |
|--|--|

INTEGRATED DELUGE SKID

MODEL DPACK



DIMENSIONS

SIZE	A	B	C	D	E	F	G	H	I
200 NB	1600	950	360	329	605	1806	2092	870	1100
150 NB	1300	800	310	301	350	1380	1642	770	1000
100 NB	1050	700	285	290	350	1366	1652	670	750
80 NB	950	700	280	290	350	1289	1602	670	650
50 NB	950	700	280	290	350	1200	1602	670	650

LIMITED WARRANTY

HD FIRE PROTECT PVT. LTD. hereby referred to as HD FIRE warrants to the original purchaser of the fire protection products manufactured by HD FIRE and to any other person to whom such equipment is transferred, that such products will be free from defect in material and workmanship under normal use and care, for two (2) years from the date of shipment by HD FIRE. Products or Components supplied or used by HD FIRE, but manufactured by others, are warranted only to the extent of the manufacturer's warranty. No warranty is given for product or components which have been subject to misuse, improper installation, corrosion, unauthorized repair, alteration or un-maintained. HD FIRE shall not be responsible for system design errors or improper installation or inaccurate or incomplete information supplied by buyer or buyer's representatives.

HD FIRE will repair or replace defective material free of charge, which is returned to our factory, transportation charge prepaid, provided after our inspection the material is found to have been defective at the time of initial shipment from our works. HD FIRE shall not be liable for any incidental or consequential loss, damage or expense arising directly or indirectly from the use of the product including damages for injury to person, damages to property and penalties resulting from any products and components manufactured by HD FIRE. HD FIRE shall not be liable for any damages or labour charges or expense in making repair or adjustment to the product. HD FIRE shall not be liable for any damages or charges sustained in the adaptation or use of its engineering data & services. In no event shall HD Fire's product liability exceed an amount equal to the sale price.

The foregoing warranty is exclusive and in lieu of all other warranties and representation whether expressed, implied, oral or written, including but not limited to, any implied warranties or merchantability or fitness for a particular purpose. All such other warranties and representations are hereby cancelled.

NOTICE :

The equipment presented in this bulletin is to be installed in accordance with the latest publication standards of NFPA or other similar organisations and also with the provision of government codes or ordinances wherever applicable.

The information provided by us are to the best of our knowledge and belief, and are general guidelines only. Site handling and installation control is beyond our reach. Hence we give no guarantee for result and take no liability for damages, loss or penalties whatsoever, resulting from our suggestion, information, recommendation or damages due to our product.

Product development is a continuous programme of HD FIRE PROTECT PVT. LTD. and hence the right to modify any specification without prior notice is reserved with the company.



C-3/6, THE NANDANVAN IND. ESTATE, L.B.S. MARG, THANE 400 604, INDIA.
PHONE : +(91) 22 2582 6958, 2582 6793
FAX : +(91) 22 2581 2524, 6796 9049
EMAIL : info@hdfire.com
WEBSITE : www.hdfire.com