

Description

Usually, a dry alarm valve station comprise:

- a Rolland dry pipe valve linked to the water motor gong.
- a set of valves and by pass used to test the water motor gong and to operate the differential check valve without overrunning the system by water.
- a drain valve.
- a pressure switch.
- gauges to measure the pressure of the water supply line and the air pressure of the system side.
- an accelerator can be added to get a faster response time of the dry pipe (optional).

Description of the dry alarm valve station is general. Before each installation of dry alarm valve station you have to refer to the required standards (Factory Mutual or others).

Valve operation

Dry alarm valve stations are used in systems of automatic fire sprinkler protection when buildings are may be exposed to freezing temperatures. Various accessories are available to meet the standards required by the authorities.

The heat resulting from a fire makes the sprinklers bulbs exploding. All air maintained inside the piping system is evacuated. When the air pressure is under the clapper opening pressure, the clapper raises, allowing water to enter the system, including the alarm device. The water motor gong is operating. An accelerator will enable a faster clapper opening at a lower pressure differential.

Specifications

Diameter	4"	6"
Connexion	flange/grooved	flange/flange
Flange type	PN 16	PN 16
Colour	Orange-red (RAL 2002)	Orange-red (RAL 2002)
Height (cm)	37,80	49,00
Weight (kg)	55,00	112,00
Approval	F.M.	F.M.
Reference	POSTEAIR4"	POSTEAIR6"

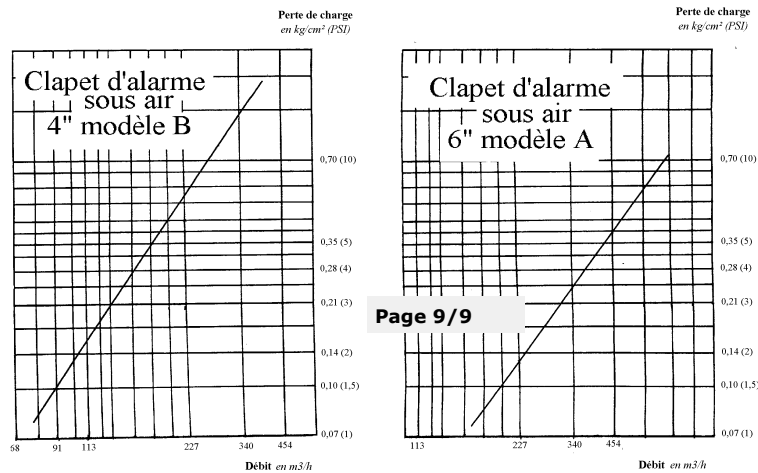

Removing the system from service

WARNING: The system should only be removed from service for maintenance and repairs. All the area concerned by the alarm valve station must be under control until the system is back in service. Advise all authorities having jurisdiction of the fire system removal, first to secure the area and secondly to avoid troubles due to false alarms during repair and maintenance.

- 1 - Close the main supply valve of the fire sprinkler system.
- 2 - Close the air supply valve (V3) of the dry alarm valve.
- 3 - Remove from service the accelerator (optional) by closing its valves. Drain the accelerator (follow instructions according to accelerator specifications).
- 4 - Open the drain valve (V5) of the dry pipe valve until the water flood completely stops.
- 5 - Remove priming water plug (BN2) (or priming water valve, depending on trim kits) in order to suppress air pressure. Gauges of the dry alarm valve should indicate zero (no pressure).
- 6 - Install a panel close to the dry alarm valve station to inform of the system removal from service.

Maintenance and solutions

- 1 If the water motor gong does not operate during the alarm test, the system piping of the alarm device must be checked up, the water motor gong and its filter must be cleaned.
- 1 If priming water is leaking in the drain cup, it means that the clapper is not waterproof. In this case you might have to clean up the clapper seat and to change the rubber gaskets of the dry pipe.
- 1 If the dry alarm valve station is operating without any sprinklers activation or test point (and auxiliary drain valve) opening, make sure that the entire trimming is correctly assembled by referring to the drawing of this brochure. Make sure that all accessories were in right position for dry alarm valve station service. Make sure that the air maintenance device is correctly operating and make sure that the clapper is still waterproof.

Follow maintenance and inspections required by Authorities having jurisdiction (fixed dates for changing rubber gaskets on valves, ...).

Procedure after a fire

Warning: be sure that the fire is completely extinguished by visiting all the buildings covered by the sprinkler system. Keep watch these buildings until the system is not back in service

1. Close the main supply valve of the fire sprinkler system.
- 2 - Change all the sprinklers that have operated during the fire. Renew these sprinklers by sprinklers which have exactly the same characteristics (temperature, upright or pendent, ...). Use the special sprinkler wrench to replace the sprinklers. Never install a sprinkler that could have been shocked. Never try to repair a sprinkler. Never try to paint a sprinkler.
- 3 - Close the valve V3 of the alarm valve device.
- 4 - *Remove from service the accelerator (optional) by shutting off its valves. Drain the accelerator (see accelerator instructions).*
- 5 - Close the air supply valve (V3) of the dry alarm valve station.
- 6 - open the drain valve (V5) of the dry alarm valve station until water flood stops. Drain the complete system and open the test point and all auxiliary drain valves of the fire sprinkler system. Make sure that any components of the system subjected to freezing temperatures is fully drained.
- 7 - Remove the cover plate of the dry pipe valve for resetting.
- 8 - Raise clapper of seat and take out any scale or solid particles found in intermediate chamber, also in the bottom of the valve, between the air and water seats. Lip the surfaces with a clean cloth of the rubber seats on the swinging clapper, also the tin seats inside the valve.
- 9 - Let bronze clapper down on its seat making sure that the rubber air ring presses evenly around the air seat.
- 10 - Put on the cover plate of the dry pipe valve making sure that gasket is in good condition. Replace nuts and tighten evenly and progressively.
- 11 - Close the drain valve (V5) of the dry alarm valve station. Close the test point valve and all auxiliaries drain valves of the sprinkler system.
- 12 - Open the priming cup valve (V2) of the dry pipe valve. Slowly put water in this cup in order to get a water surface on the clapper.
- 13 - Remove priming water plug (BN2) (or priming water valve, depending on trim kits). It will allow getting the exact quantity of water required above the clapper.
- 14 - After water flood stops, replace priming water plug (BN2) (or priming water valve, depending on trim kits) . Water must not stand above priming cup level.
- 15 - Close the priming cup valve (V2).
- 16 Open the air supply valve (V3) and pump air into the fire sprinkler system. When the air pressure has reached 1 Bar (14.5 PSI), close this valve (V3) in order to stop the compressor.

Open the test point valve and all auxiliary drain valves of the fire sprinkler system in order to evacuate any water that could have stayed in the system. Once this operation completed, close all these valves.

18 - Open again the air supply valve (V3) and pump air pressure into the system according to the following table:

Note: Never allow air pressure to drop below the minimum limit, to safeguard against accidental tripping of the dry alarm valve station.

Maximum water pressure		Air pressure			
		Minimum		Maximum	
PSI	BARS	PSI	BARS	PSI	BARS
50	3.45	20	1.38	35	2.41
75	5.17	25	1.72	40	2.76
100	6.90	30	2.07	45	3.10
125	8.62	35	2.41	50	3.45
150	10.34	45	3.10	50	3.45

19 - Depending on your system, close the air supply valve (V3) or make sure of the good operation of your air maintenance device.

20 - Make sure there is no leakage of priming water by the rubber air seat into the dry cup by checking up the automatic drain valve (RN).

21 - Slowly open the accelerator valves. The air pressure gauge installed on the top of the accelerator should indicate the air pressure. Check up again the automatic drain valve (RN).

22 - Open slowly but completely the water supply valve. Make sure that no water floods from automatic drain valve (RN).

23-- Open the valve (V3) of the alarm device and seal it. If this valve is not opened, the water motor gong will not be able to operate.

Inspections and tests

WARNING: The system should only be removed from service for maintenance and repairs. All the area concerned by the alarm valve station must be under control until the system is back in service. Advise all authorities having jurisdiction of the fire system removal, first to secure the area and secondly to avoid troubles due to false alarms during repair and maintenance.

You must follow the rules and advises of Authorities having jurisdiction and to apply their decisions.

Inspections and tests must be done each time defined in the authorised rules. Most of the time these tests and inspections are made weekly, quarterly, annually, ...

Only inspections and tests made weekly and quarterly are given, on a general view, in this brochure. Any inspection must also be completed by a visual control in order to see possible physical troubles on the equipment (shocks, freezing problems, corrosion, ...).



Description of accessories positions for dry alarm valve station service

- . The main supply valve is fully opened and sealed.
- . Gauge valves are opened (V1 and V1).
- . Valve of the alarm device is opened (V5). It is the same for pressure.
- . Alarm valve test (V3) is closed.
- . Drain valve (V7) is closed.
- . Priming cup valve (V5) is closed.
- . Water priming plug (BN2) is in place (or water priming valve is closed, depending on your trim kits).
- . Water (M1) and air (M2) pressures are respecting the table given in this brochure (& 18 of procedure after a fire).
- . *Accelerator valves are fully opened (optional). Accelerator gauge is indicating the same pressure as the air pressure gauge (M1) of the dry pipe valve.*
- . Air supply is correctly installed (valve closed or air maintenance device operating).

Weekly tests and inspections

- 1 - Check up that the dry alarm valve station is in service (see above paragraph).
- 2 - Make a test of the alarm valve device by opening the valve (V3). The water motor gong should be operating and ring.
- 3 - Check up that no water is flooding in the drain cup of the priming water. Make sure that the automatic drain valve is correctly operating (RN).

Miscellaneous tests

- 1 - Priming water test:
 - . Close the main supply valve.
 - . *Close the accelerator valves (optional).*
 - . Open the drain valve (V5) of the dry pipe valve.
 - . Close all air supply of the sprinkler system.
 - . Remove priming water plug (BN2) (or priming water valve, depending on trim kits). If water is flooding, it means that the sprinkler system has not been correctly drained or that procedures after a fire have not been correctly done. In these case, start again the "procedure after a fire" after having completely drained the sprinkler system.
 - . If no water is flooding, replace the priming water plug (BN2) (or priming water valve, depending on trim kits) and follow the instructions of the "procedure after a fire" on point 18.
- 2 - Trip test of the dry valve station:
 - . Open the drain valve (V5) of the dry pipe valve.
 - . once water is clear, close this drain valve (V5).
 - . note the water pressure on the water gauge (M1).
 - . open the test point valve on the sprinkler system to simulate sprinkler activation. Let the water flood until it becomes clear.
 - . Note all data required by Authorities having jurisdiction (response time of the dry pipe vale, time for the water to reach the test point, ...).
 - . Make sure that all alarms are correctly operating.
 - . If everything is correct, follow the instruction of the "procedure after a fire".

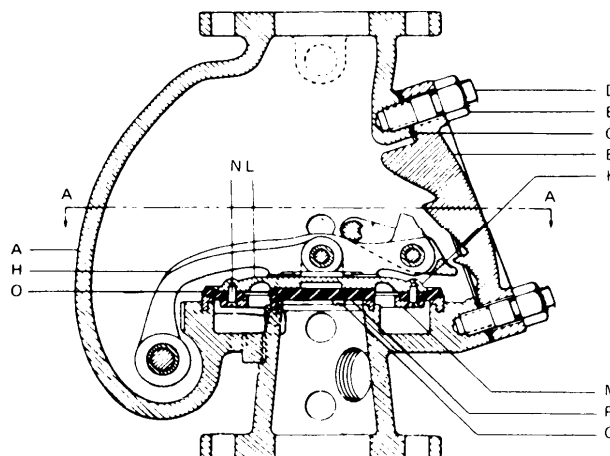
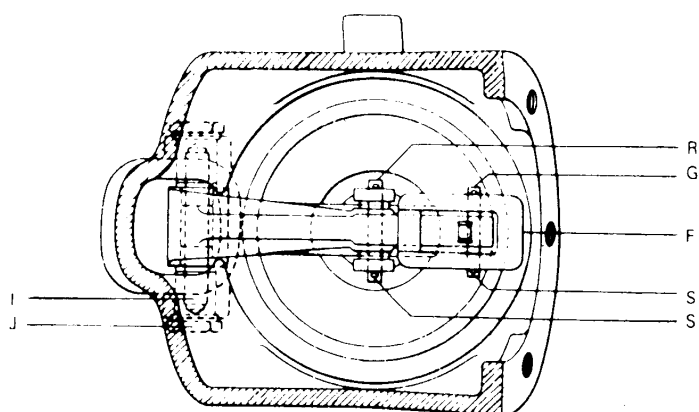

Rference	Dry pipe valve 4" F.M.	Dry pipe valve 6" F.M.	Description
A	4A.1	6A.1	Body
B	4A.3	6A.3	Cover plate
C	4A.4	6A.4	Cover gasket
D	4A.5	6A.5	Cover bolt
E	4A.6	6A.6	Cover nut
F	4A.10	6A.10	Latch
G	4A.11	6A.11	Latch pin
H	4A.12	6A.12	Clapper arm
I	4A.13	6A.13	Clapper arm pin
J	4A.14	6A.14	Clapper arm pin plug
K	4A.7	6A.7	Clapper assembly
L	4A.8	6A.8	Clapper
M	4A.9	6A.9	Clapper ring
N	4A.15	6A.15	Clapper screw
O	4A.16	6A.16	Rubber air seat gasket
P	4A.17	6A.17	Rubber water seat gasket
Q	4A.18	6A.18	Clapper disc screw
R	4A.19	6A.19	Pin clapper arm/disk
S	4A.20	6A.20	Cotter pin clapper pin/ clapper arm

ALARM VALVES

DRY VALVE TRIM 4" / POSTE AIR 4" MODEL B -FM - V4

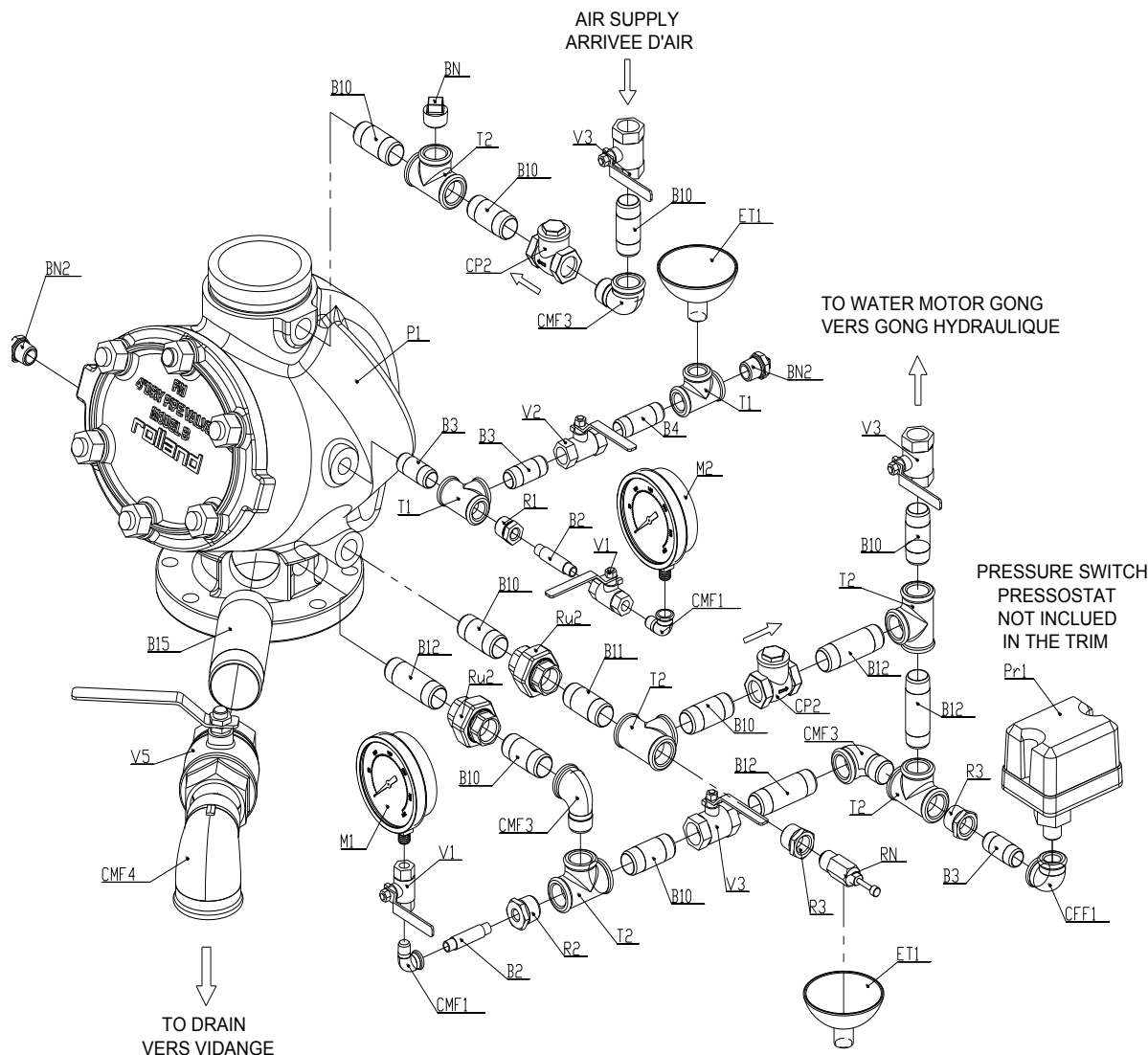

ALARM VALVES

Ref	Description	Qty
B2	Nipple 1/4"x60	2
B3	Nipple 1/2"x50	3
B4	Nipple 1/2"x60	1
B10	Nipple 3/4"x50	8
B11	Nipple 3/4"x60	1
B12	Nipple 3/4"x80	4
B15	Nipple 2"x150	1
T1	Tee equal 1/2"	2
T2	Tee equal 3/4"	5
CMF1	Elbow MF 90° 1/4"	2
CMF3	Elbow MF 90° 3/4"	3
CMF4	Elbow MF 90° 2"	1
CF1	Elbow FF 90° 1/2"	1
CP2	Clapper FF 3/4"	2

Ref	Description	Qty
M1	Manometer water 1/4"	1
M2	Manometer air 1/4"	1
R1	Reducing nipple 1/2"M>1/4"F	1
R2	Reducing nipple 3/4"M>1/4"F	1
R3	Reducing nipple 3/4"M>1/2"F	2
Ru2	Union 3/4" FF	2
V1	Valve 1/4"	2
V2	Valve 1/2"	1
V3	Valve 3/4"	3
V5	Valve 2"	1
RN	Automatic ball drip 1/2"	1
ET1	Drip cup 1/2"	2
BN	Plug 3/4"	1
BN2	Plug 1/2"	2
Pr1	Pressure switch	1

Dimensions (mm)	
Width	580
Depth	410
Height	490

**DRY VALVE TRIM 4" WITH ACCELERATOR B1
POSTE AIR 4" AVEC ACCELERATOR B1 - MODEL A -FM - V2**

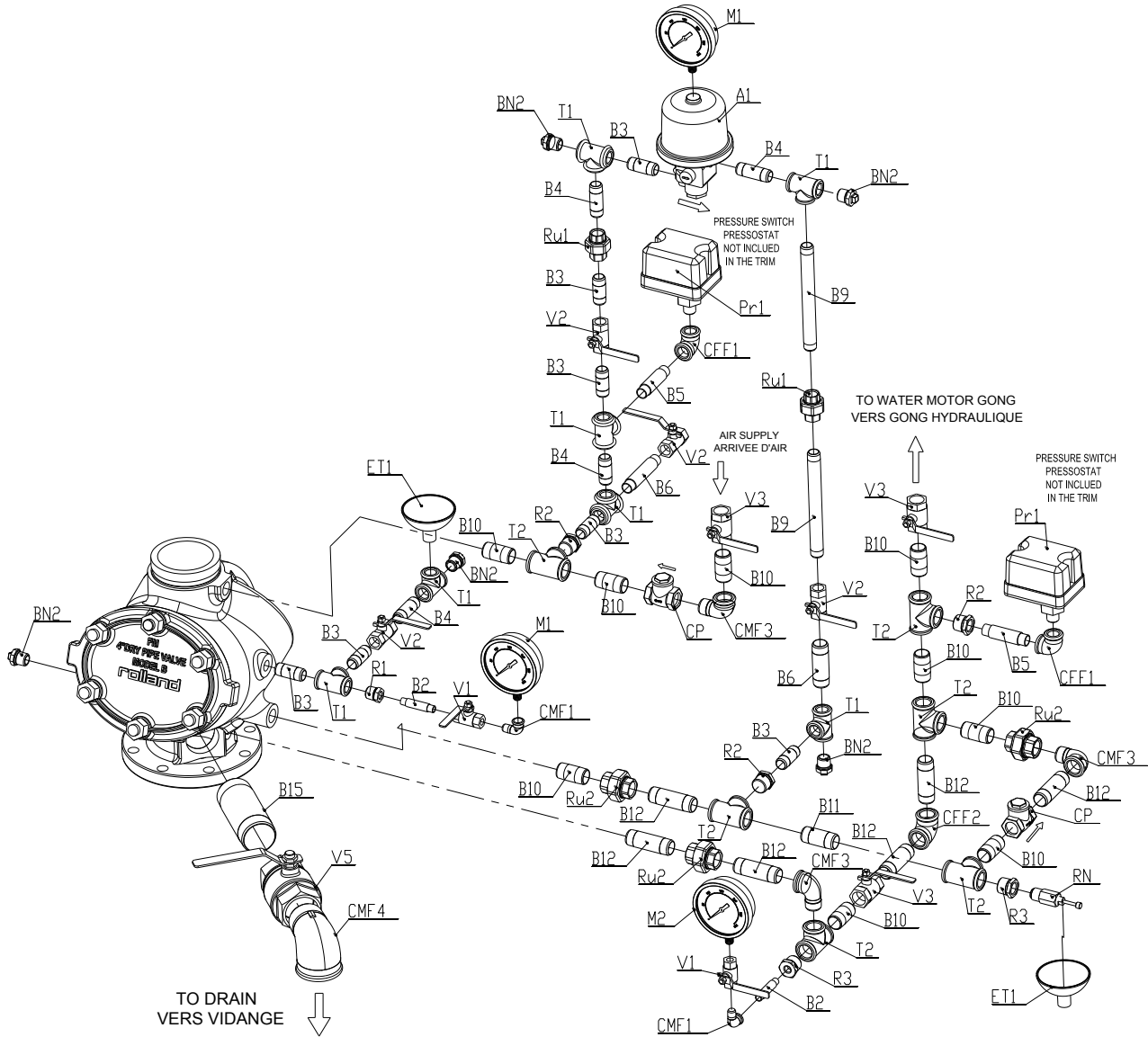

Ref	Désignation	Qty
A1	Accelerator	1
BN2	Plug	1/2" 5
B1	Nipple	1/4"x60 2
B2	Nipple	1/2"x50 7
B3	Nipple	1/2"x60 4
B5	Nipple	1/2"x80 2
B6	Nipple	1/2"x100 2
B9	Nipple	1/2"x200 2
B10	Nipple	3/4"x50 9
B11	Nipple	3/4"x60 1
B12	Nipple	3/4"x80 6
B15	Nipple	2"x150 1

Ref	Description	Qty
CP	Clapper FF	3/4" 2
CFF1	Elbow FF 90°	1/2" 2
CFF2	Elbow FF 90°	3/4" 1
CMF1	Elbow MF 90°	1/4" 2
CMF3	Elbow MF 90°	3/4" 3
CMF4	Elbow MF 90°	2" 1
ET1	Drip cup	1/2" 2
M1	Mano air	2
M2	Mano water	1
R1	Reducing nipple	1/2"M>1/4"F 1
R2	Reducing nipple	3/4"M>1/2"F 4

Ref	Description	Qty
R3	Reducing nipple	3/4"M>1/4"F 1
RN	Automatic ball drip	1/2" 1
T1	Tee equal	1/2" 7
T2	Tee equal	3/4" 6
Ru1	Union	1/2" FF 2
Ru2	Union	3/4" FF 3
V1	Valve	1/4" 2
V2	Valve	1/2" 4
V3	Valve	3/4" 3
V5	Valve	2" 1
Pr1	Pressure switch	2

Dimensions (mm)	
Width	700
Depth	600
Height	980

ALARM VALVES

DRY VALVE TRIM 6" / POSTE AIR 6" MODEL A - FM - V4

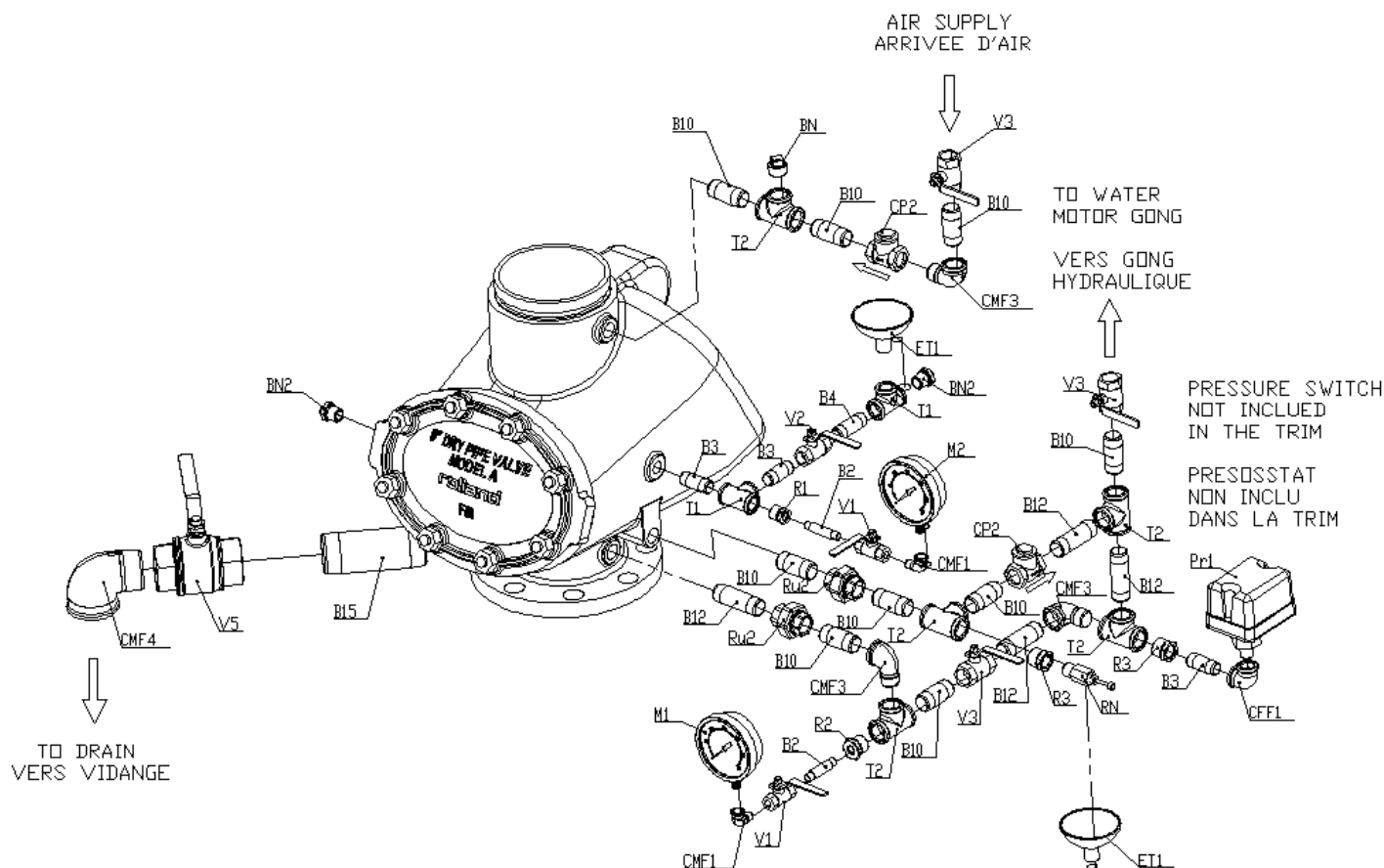

ALARM VALVES

Ref	Description	Qty
B2	Nipple 1/4"x60	2
B3	Nipple 1/2"x50	3
B4	Nipple 1/2"x60	1
B10	Nipple 3/4"x50	9
B12	Nipple 3/4"x80	4
B15	Nipple 2"x150	1
T1	Tee equal 1/2"	2
T2	Tee equal 3/4"	5
CMF1	Elbow MF 90° 1/4"	2
CMF3	Elbow MF 90° 3/4"	3
CMF4	Elbow MF 90° 2"	1
CFF2	Elbow FF 90° 3/4"	1
CP2	Clapper FF 3/4"	2
M1	Mano water 1/4"	1

Ref	Description	Qty
M2	Mano air 1/4"	1
R1	Reducing nipple 1/2"M>1/4"F	1
R2	Reducing nipple 3/4"M>1/4"F	1
R3	Reducing nipple 3/4"M>1/2"F	2
Ru2	Union 3/4" FF	2
V1	Valve 1/4"	2
V2	Valve 1/2"	1
V3	Valve 3/4"	3
V5	Valve 2"	1
RN	Automatic ball drip 1/2"	1
ET1	Drip cup 1/2"	2
BN	Plug 3/4"	1
BN2	Plug 1/2"	2
Pr1	Pressure switch	1

Dimensions (mm)	
Width	580
Depth	500
Height	500

**DRY VALVE TRIM 6" WITH ACCELERATOR B1
POSTE AIR 6" AVEC ACCELERATOR B1
MODEL A - FM -V2**

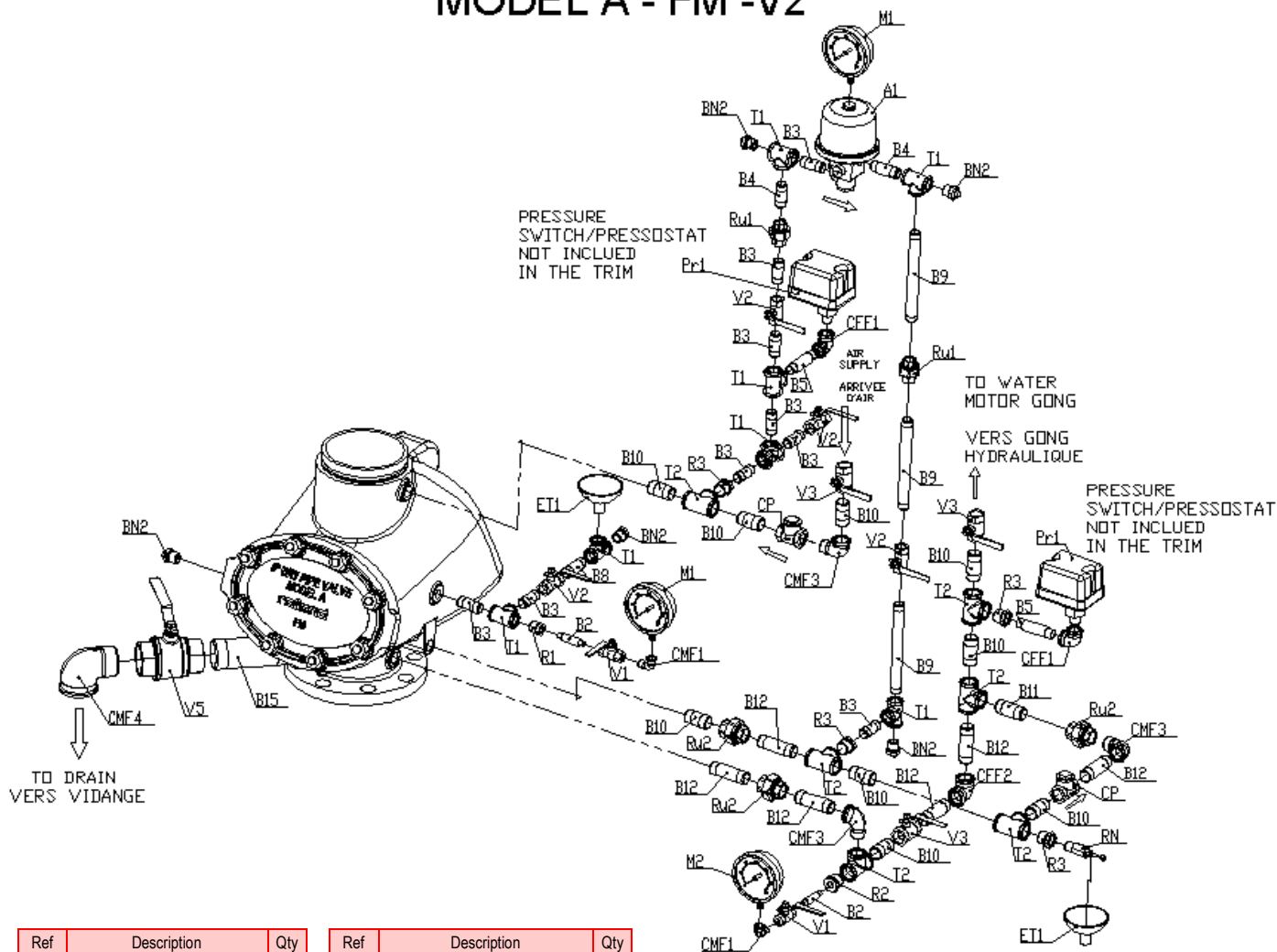

ALARM VALVES

Ref	Description	Qty
A1	Accelerator	1
BN2	Plug 1/2"	5
B2	Nipple 1/4"x60	2
B3	Nipple 1/2"x50	9
B4	Nipple 1/2"x60	2
B5	Nipple 1/2"x80	2
B8	Nipple 1/2"x150	1
B9	Nipple 1/2"x200	3
B10	Nipple 3/4"x50	9
B11	Nipple 3/4"x60	1
B12	Nipple 3/4"x80	6
B15	Nipple 2"x150	1
CP	Clapper FF 3/4"	2
CFF1	Elbow FF 90° 1/2"	2
CFF2	Elbow FF 90° 3/4"	1
CMF1	Elbow MF 90° 1/4"	2
CMF3	Elbow MF 90° 3/4"	3

Ref	Description	Qty
CMF4	Elbow MF 90° 2"	1
ET1	Drip cup 1/2"	2
M1	Mano air	2
M2	Mano water	1
R1	Reducing nipple 1/2"M>1/4"F	1
R2	Reducing nipple 3/4"M>1/4"F	1
R3	Reducing nipple 3/4"M>1/2"F	4
RN	Automatic ball drip 1/2"	1
T1	Tee equal 1/2"	7
T2	Tee equal 3/4"	6
Ru1	Union 1/2" FF	2
Ru2	Union 3/4" FF	3
V1	Valve 1/4"	2
V2	Valve 1/2"	4
V3	Valve 3/4"	3
V5	Valve 2"	1
Pr1	Pressure switch	2

Dimensions (mm)	
Width	860
Depth	600
Height	1050