

**ZICO\***

**3094PM1**

# QUIC-STEP™ RETRACTABLE VEHICLE STEP



## Step-Out with Confidence

**Reduces shock injury to personnel by decreasing the distance from the ground to the step surface.**

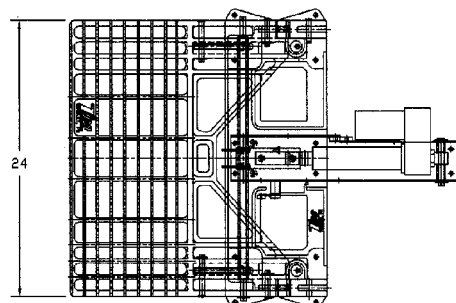
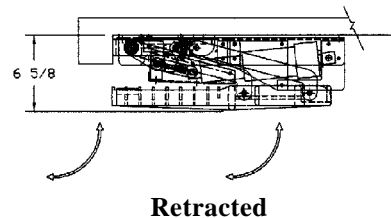
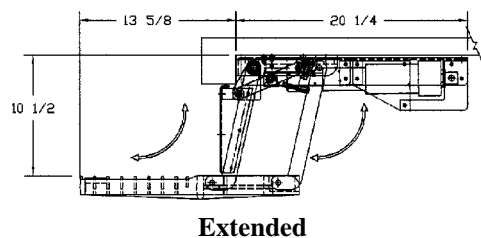
Designed specifically for use on fire and emergency vehicles. May be retrofitted onto existing apparatus.

Cast aluminum step plate 24" wide x 10-3/4" deep with a non-skid surface to provide traction and safety.



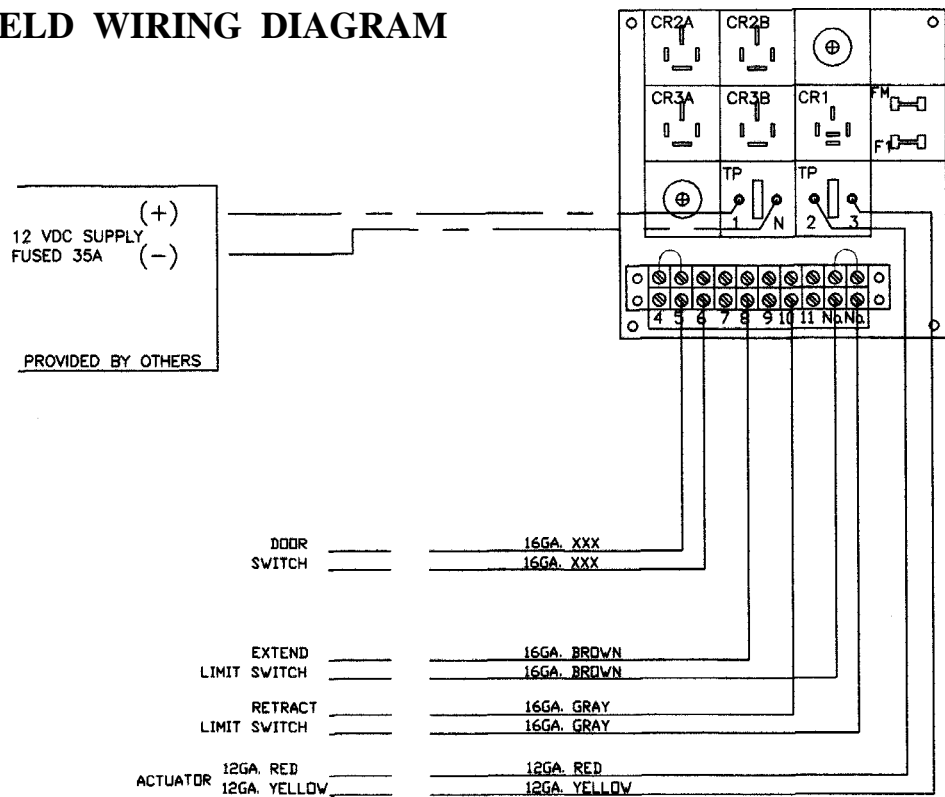
Powered by a single 12-volt electric actuator. Includes a patent pending in-line locking mechanism to hold the extended step rigidly in

place. Step may be wired into door interlock system to automatically extend with door opening and retract with door closing.

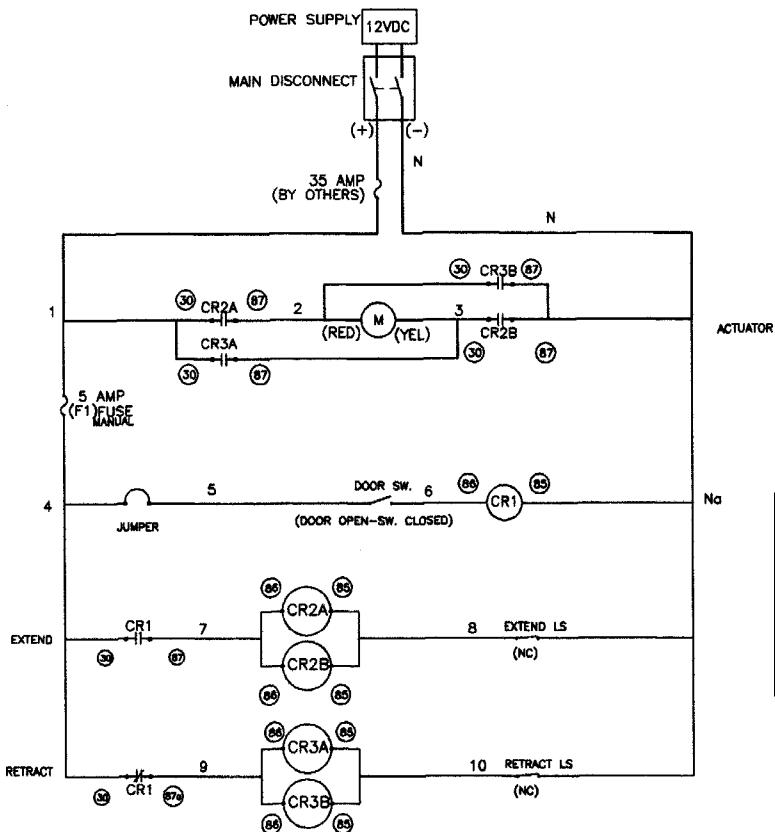


MODEL	DESCRIPTION	WT./@ IN LBS.
VS-24-11	Retractable Vehicle Step	71.0

**FIGURE 1 - FIELD WIRING DIAGRAM**



**FIGURE 2 - ELECTRICAL SCHEMATIC**



**MODE OF OPERATION**

- PROVIDE POWER TO AUTOSTEP

**EXTEND MODE:**

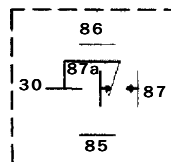
- STEP WILL AUTOMATICALLY EXTEND AS SOON AS THE DOOR IS OPENED.
- STEP WILL REMAIN EXTENDED AS LONG AS DOOR REMAINS OPEN.

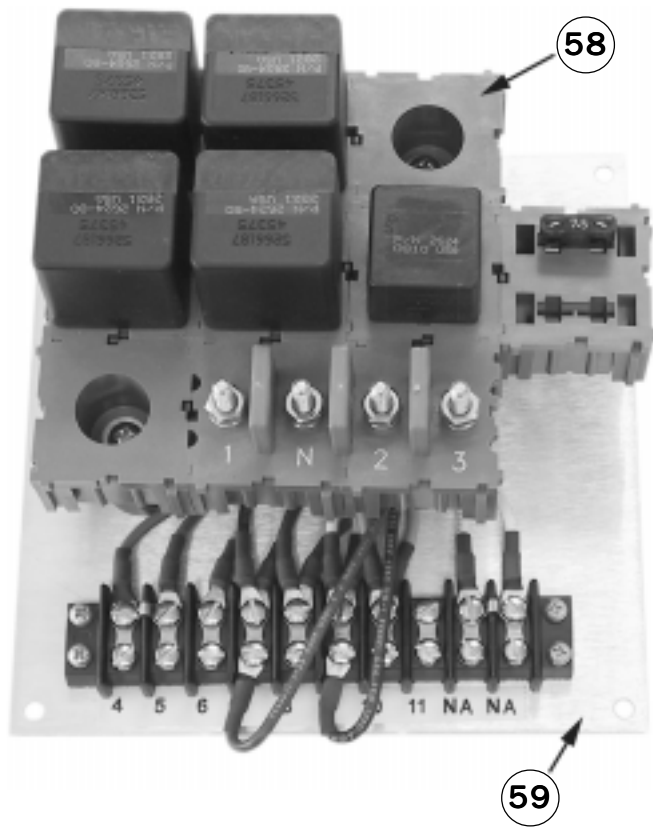
**RETRACTED MODE:**

- STEP WILL AUTOMATICALLY RETRACT AS SOON AS THE DOOR IS CLOSED.
- STEP WILL REMAIN RETRACTED AS LONG AS DOOR REMAINS CLOSED.

**NOTE:**

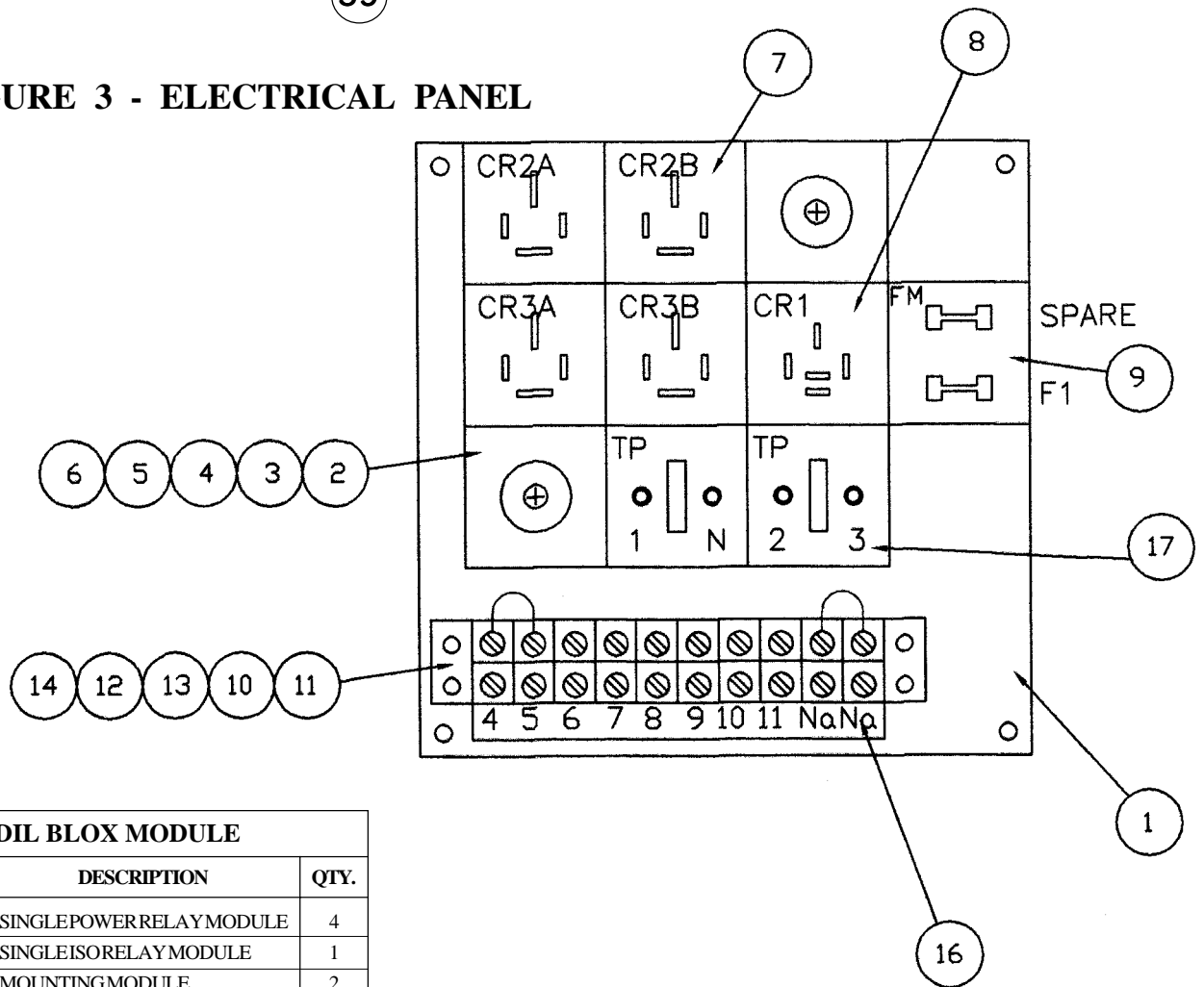
CIRCLED NUMBERS ARE NUMBERS MARKED ON DEVICE  
NON-CIRCLED NUMBERS ARE TERMINAL NUMBERS  
COLOR IN BRACKETS - DEVICE WIRE COLORS  
COLOR WITHOUT BRACKETS - WIRE LEAD COLOR





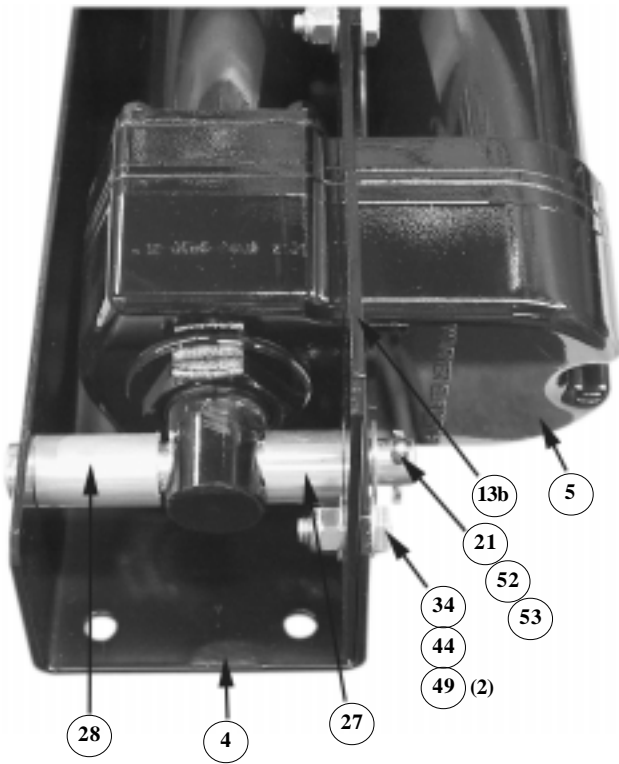
ELECTRICAL PANEL ASSEMBLY			
ITEM	PARTNO.	DESCRIPTION	QTY.
1	3094-005-150	SUB-PANEL, 6-1/2x6-1/2	1
2	3094-005-152	DIL BLOXMODULE	1
3	3094-005-154	STANDOFF#74096	2
4	9010-222024	SCREW, 10-32x1-1/2PHPHIL.	2
5	9014-202000	LOCKWASHER#10	10
6	9010-102000	HEXNUT, 10-32	10
7	3097-500-151	POWERRELAY CR2A, CR2B, CR3A, CR3B	4
8	3094-005-156	CONTROLRELAYCR1	1
9	3094-005-158	FUSE7.5A	1
10	9014-201300	LOCKWASHER#6	4
11	9010-101300	HEXNUT, 6-32	4
12	3094-005-160	TERM. BLOCK, 10 POS. CINCH 141 SERIES	1
13	9010-241310	SCREW, 6-32x5/8RD. HD., PHIL.	4
14	3094-005-162	TERM. JUMPER CINCH TYP 141J	1
15	3094-005-164	WIRINGSET	1
16	3094-005-166	TERMINAL LABEL	1
17	3094-005-168	TERMINAL MARKING	1

**FIGURE 3 - ELECTRICAL PANEL**

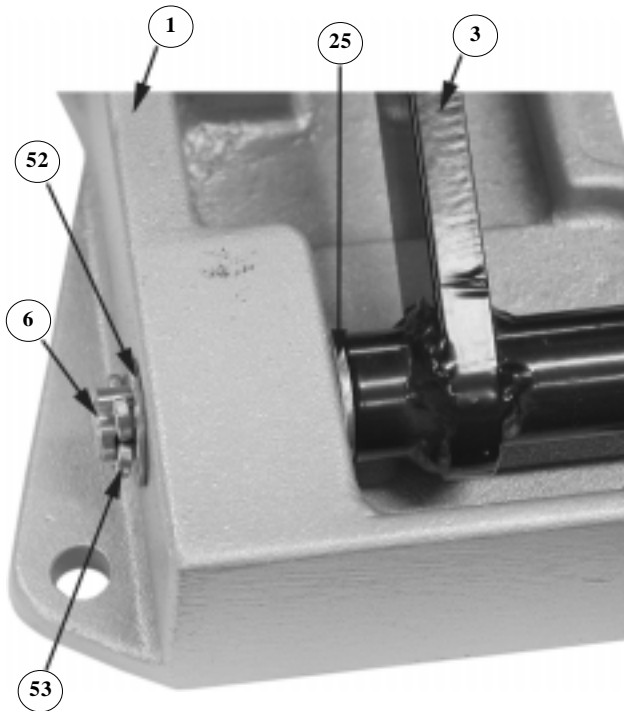


DIL BLOX MODULE		
PARTNO.	DESCRIPTION	QTY.
	SINGLEPOWERRELAYMODULE	4
	SINGLEISORELAYMODULE	1
	MOUNTINGMODULE	2
	STUDMODULEASSY.	2
	2 POS CB/FUSEMODULE	1
	LOCKINGWEDGE	13

# CHART 1



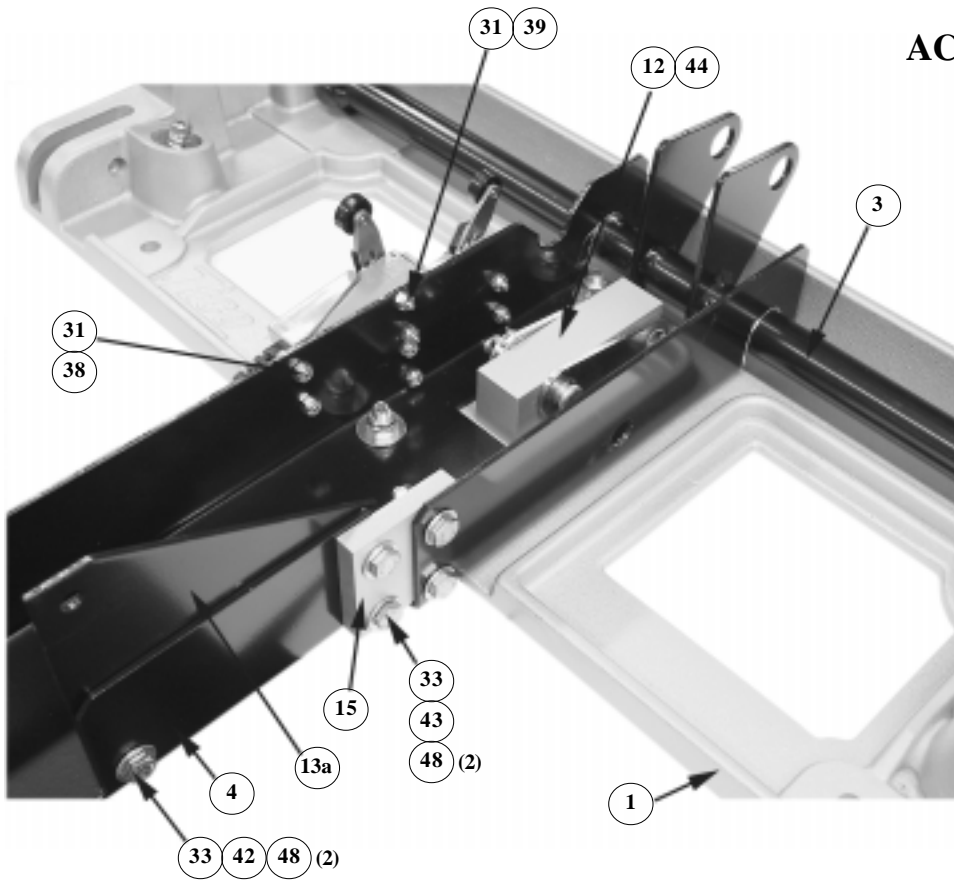
**FIGURE 4 - ACTUATOR**



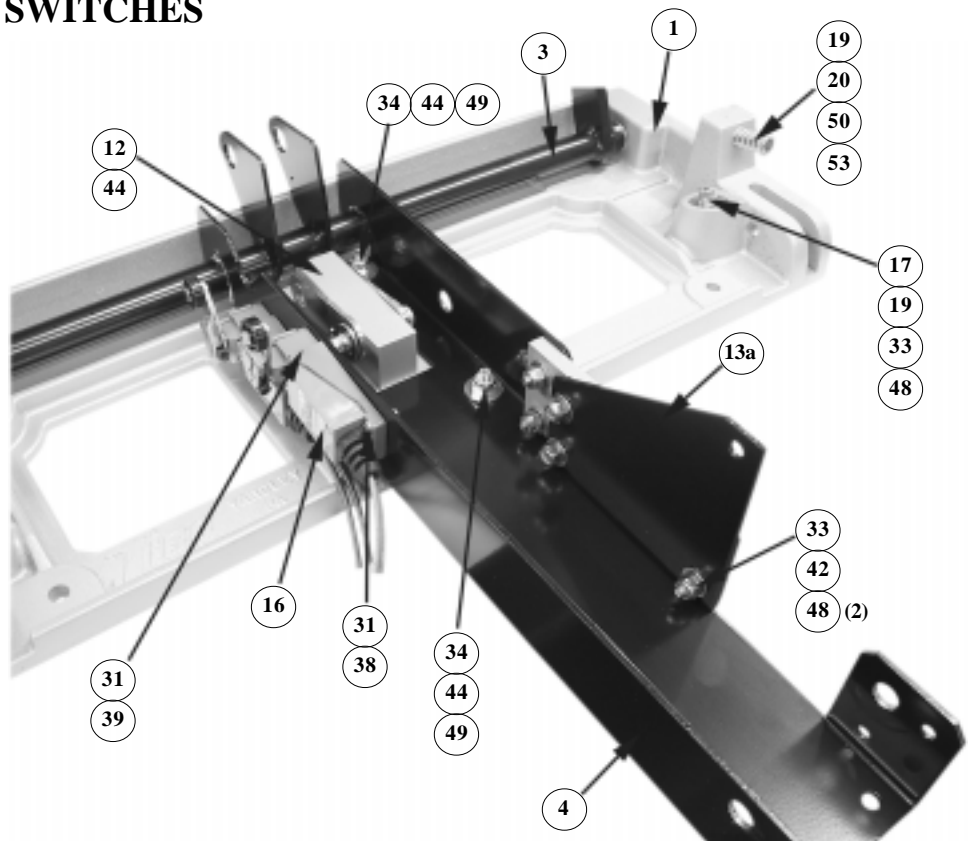
**FIGURE 5 - TORQUE TUBE**

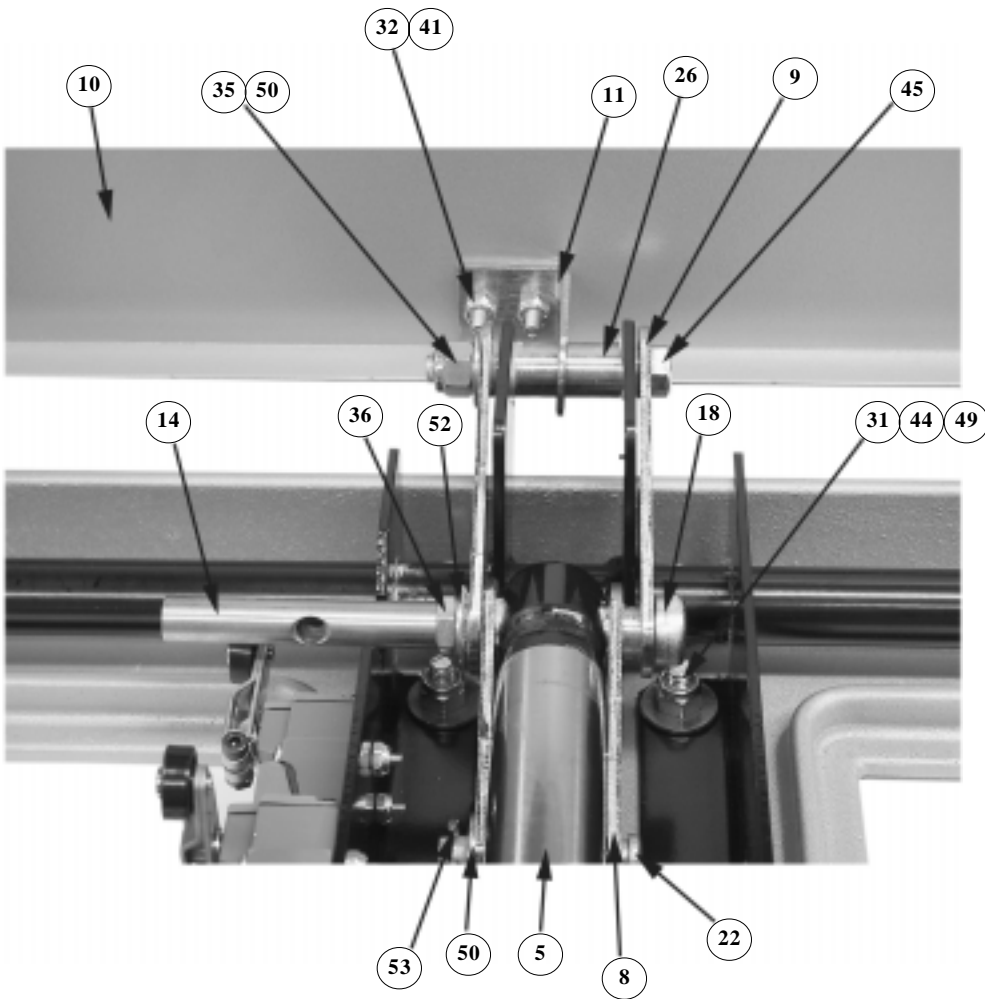
ITEM	PARTNO.	DESCRIPTION	QTY.
1	3094-005-101	BASECASTING	1
2	3094-005-103	STEPCASTING	1
3	3094-005-105	TORQUETUBE WELDMENT	1
4	3094-005-133	ACTUATOR ATTACH. BRACKET	1
5	3094-005-113	LINEAR ACTUATOR WARNER D12-05B5-04	1
6	3094-005-115	SHAFT, 1/2φ x 24" COLD DRAWN	1
7	3094-005-117	SLAVE ARM	2
8	3094-005-119	SHORT LINK	2
9	3094-005-121	LONG LINK	2
10	3094-005-123	KICK PANEL	1
11	3094-005-125	KICK PANEL BRACKET	1
12	3094-005-135	MOUNTING BLOCK, LINKAGE	1
13a	3094-005-137	STIFFENING PLATE A	1
13b	3094-005-138	STIFFENING PLATE B	1
14	3094-005-141	SWITCH EXTENSION	1
15	3094-005-143	SPACER PLATE	1
16	3097-500-181	LIMIT SWITCH	2
17	9010-313116	SHOULDER SCREW, 5/16-18 x 1	2
18	9010-315032	SHOULDER SCREW, 1/2- 13 x 2 3/8-16 TH.	1
19	3094-005-180	SPRING BUMPER LEELC-059G-5	4
20	9080-003136	CLEVIS PIN, 5/16 x 2-1/4	2
21	9080-005064	CLEVIS PIN, 1/2φ x 4	1
22	9080-003730	CLEVIS PIN, 3/8 x 1-7/8	1
23	9080-004336	CLEVIS PIN, 7/16 x 2-1/4	2
24	9080-004332	CLEVIS PIN, 7/16 x 2	2
25	3094-005-182	BUSHING SHAFT, .500 ID x 5/8 OD, .1 FL, BRONZE	2
26	3094-005-184	SLEEVE, 3/8 ID x 5/8 OD x 1.625 LG., SS	1
27	3094-005-186	SPACER, .75 OD, .781 LG. x .083 WALL, ALUM. TBG.	1
28	3094-005-188	SPACER, .75 OD x 1.25 LG. x .083 WALL, ALUM. TBG.	1
30	9080-004356	CLEVIS PIN, 7/16 x 3-1/2	2
31	9012-101300	HEX NUT, #6-32	8
32	9013-131900	HEX NUT, 10-24, FLEXLOC	8
33	9012-172500	HEX NUT, 1/4-20, ESNA LOCK NUT	10
34	9013-133100	HEX NUT, 5/16-18, FLEXLOC	6
35	9013-133700	HEX NUT, 3/8-16, FLEXLOC	1
36	9012-203700	HEX NUT, 3/8-16, JAM	1
38	9010-221310	SCREW, #6-32 x 5/8 PAN HD. PHIL.	4
39	9010-221318	SCREW, #6-32 x 1-1/8, PAN HD. PHIL.	4
41	9010-222012	SCREW, #10-24 x 3/4, PHIL. HD.	8
42	9010-102512	SCREW, 1/4-20 x 3/4, HEX HD.	4
43	9010-102516	SCREW, 1/4-20 x 1, HEX HD.	4
44	9010-163116	SCREW, 5/16-18 x 1, FLAT HD. PHIL.	8
45	9010-103740	SCREW, 3/8-16 x 2-1/2, HEX HD.	1
48	9014-112500	WASHER, 1/4φ NOM.	16
49	9014-113100	WASHER, 5/16φ NOM.	6
50	9014-113700	WASHER, 3/8φ NOM.	4
51	9014-114300	WASHER, 7/16φ NOM	6
52	9014-115000	WASHER, 1/2φ NOM	3
53	9070-001212	COTTER PIN, 1/8 x 3/4	11
58	3094-005-148	ELECTRICAL PANEL ASSY.	1
59	3094-005-150	SUB PANEL	1
60	0000-000-112	SERIAL NUMBER LABEL	1
61	9120-101103	DRIVE SCREW #4 x 3/16 TYPE U	2

**FIGURE 6 -  
ACTUATOR RETAINER  
BRACKET**



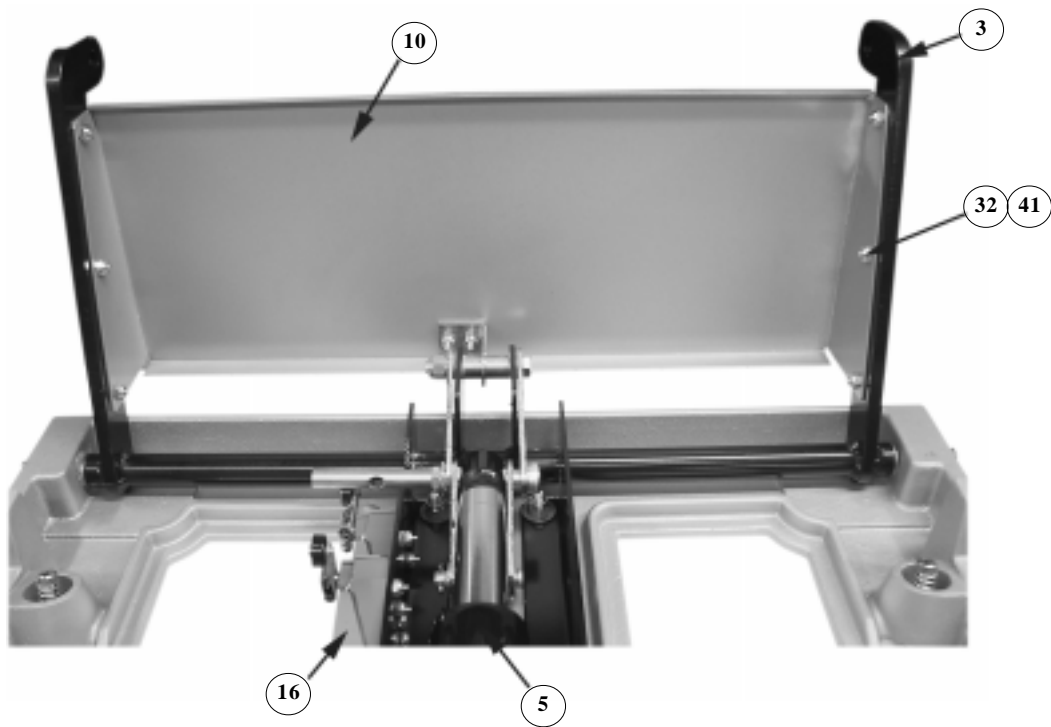
**FIGURE 7 - MICRO SWITCHES**

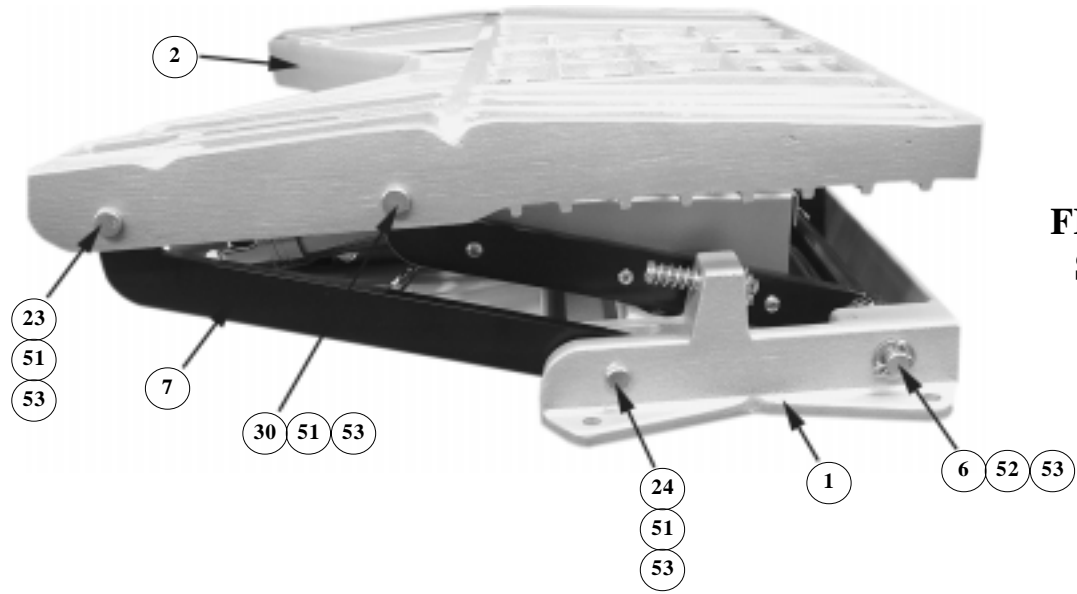




**FIGURE 8 -  
LOWER ASSEMBLY**

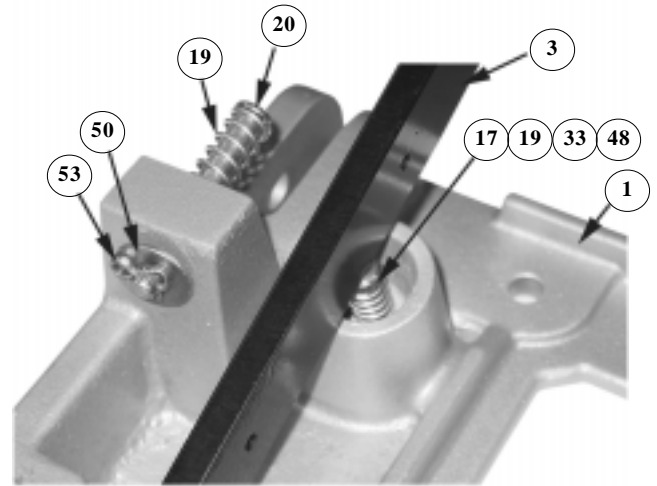
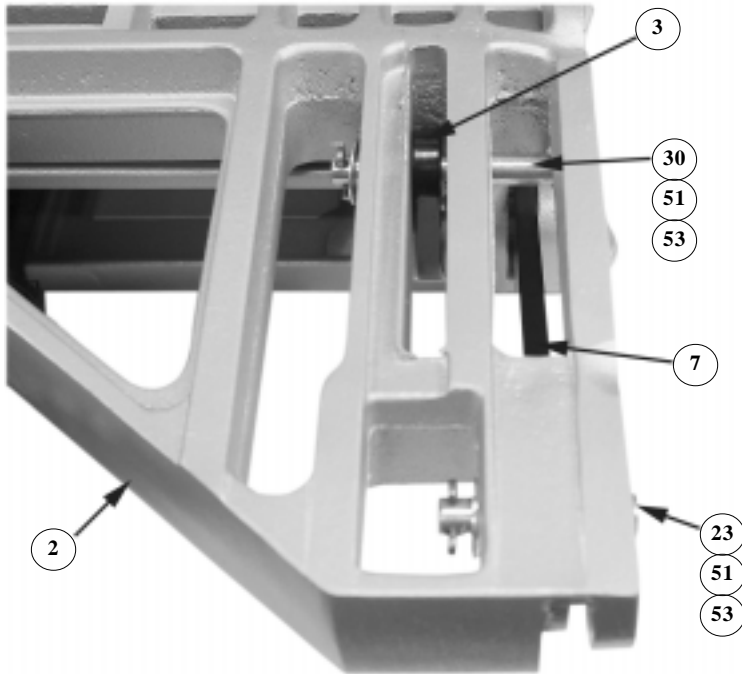
**FIGURE 9 - KICK PLATE ATTACHMENT**





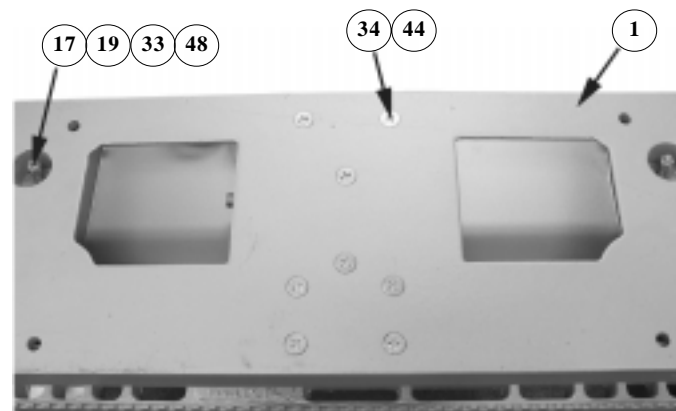
**FIGURE 10 -  
SIDE VIEW**

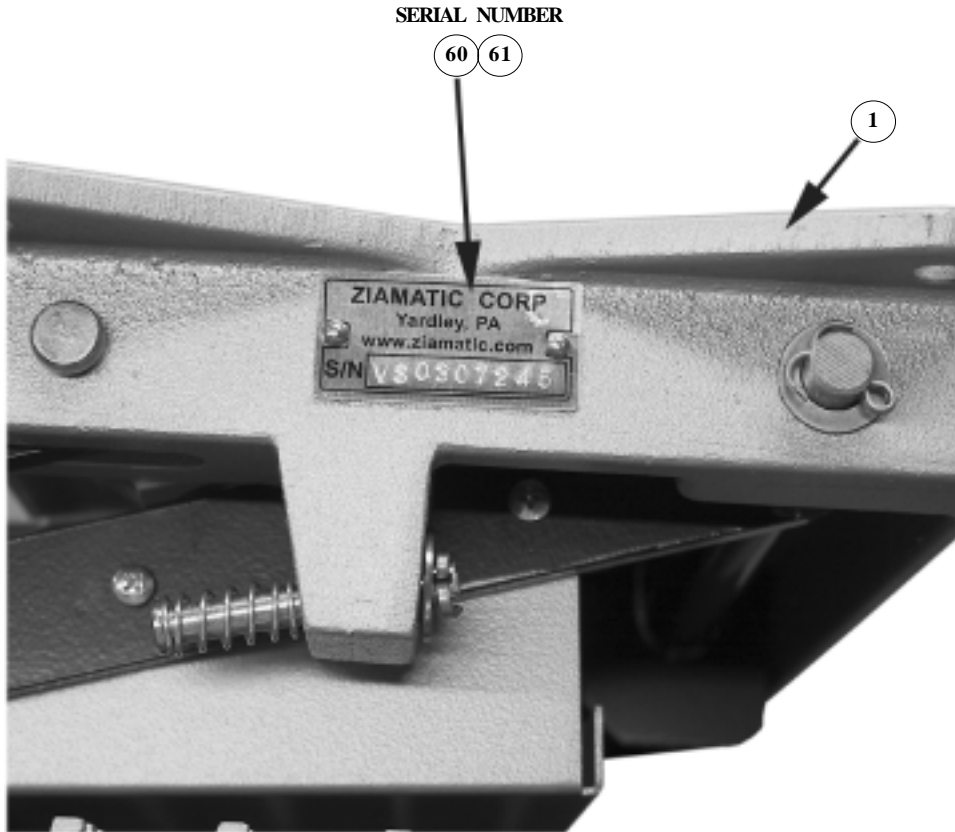
**FIGURE 11 - STEP**



**FIGURE 12 - SPRINGS**

**FIGURE 13 - UNDERSIDE OF BASE**





**FIGURE 14 - SERIAL NUMBER LABEL**



*Ziamatic Corp.*

10 West College Avenue, P.O. Box 337, Yardley, PA 19067-8337 • (215) 493-3618 • FAX: (215) 493-1401

\*ZICO is a registered trademark for fire, safety and marine products made by Ziamatic Corp.

WWW.ZIAMATIC.COM  
CALL TOLL FREE: 800-711-FIRE

Copyright Ziamatic Corp. 8-03