

PUMPHÜBE (PUMP STROKE)

ÖFFNEN (OPENING) 14 HÜBE (STROKE)

SCHLIESSEN (CLOSING) 17 HÜBE (STROKE)

WERKZEUGKOPF 360° SCHWENKBAR (CUTTING BLADES 360° ROTABLE)

TEMPERATURBEREICH (WORKING TEMPERATURE) -30°C - 80°C

MAX. HANDKRAFT (MAX. OPERATING FORCE AT PUMP LEVEL) ca. 300 N

GEWICHT INKL. ÖL (WEIGHT INCL. OIL) .. 11,2 kg

KLASSE (CLASS)

DIN 14751-4 K 25E-M

IN ANLEHNUNG AN (FOLLOWING) EN 13204 . BK 26/260-E-11

NFPA 1936 A6,B6,C6,D7,E7

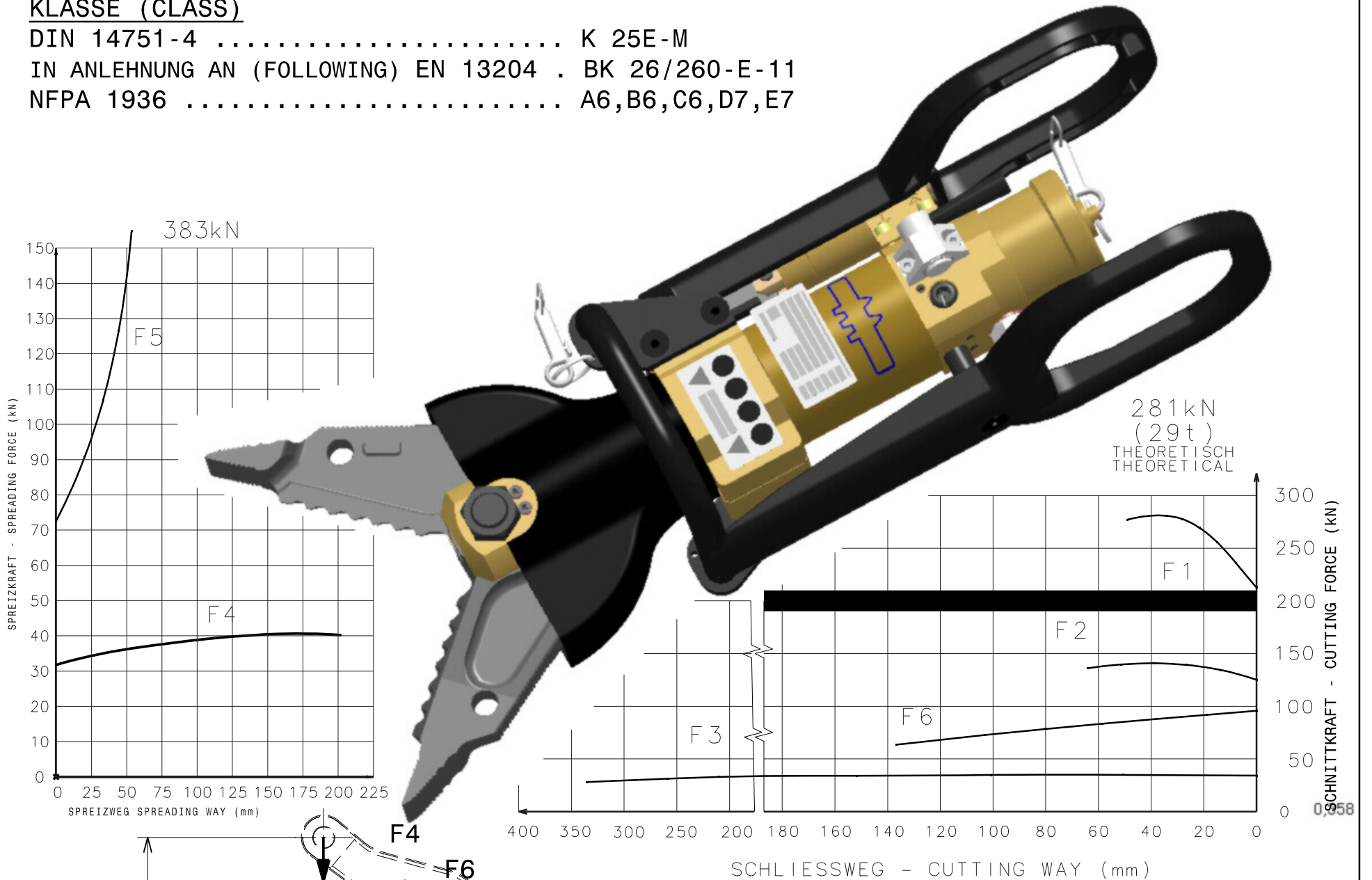

ALLE KRÄFTE BEI 63 MPa U. OHNE WIRKUNGSGRAD
DIAGRAMM AT 63 MPa AND WITHOUT EFFICIENCY

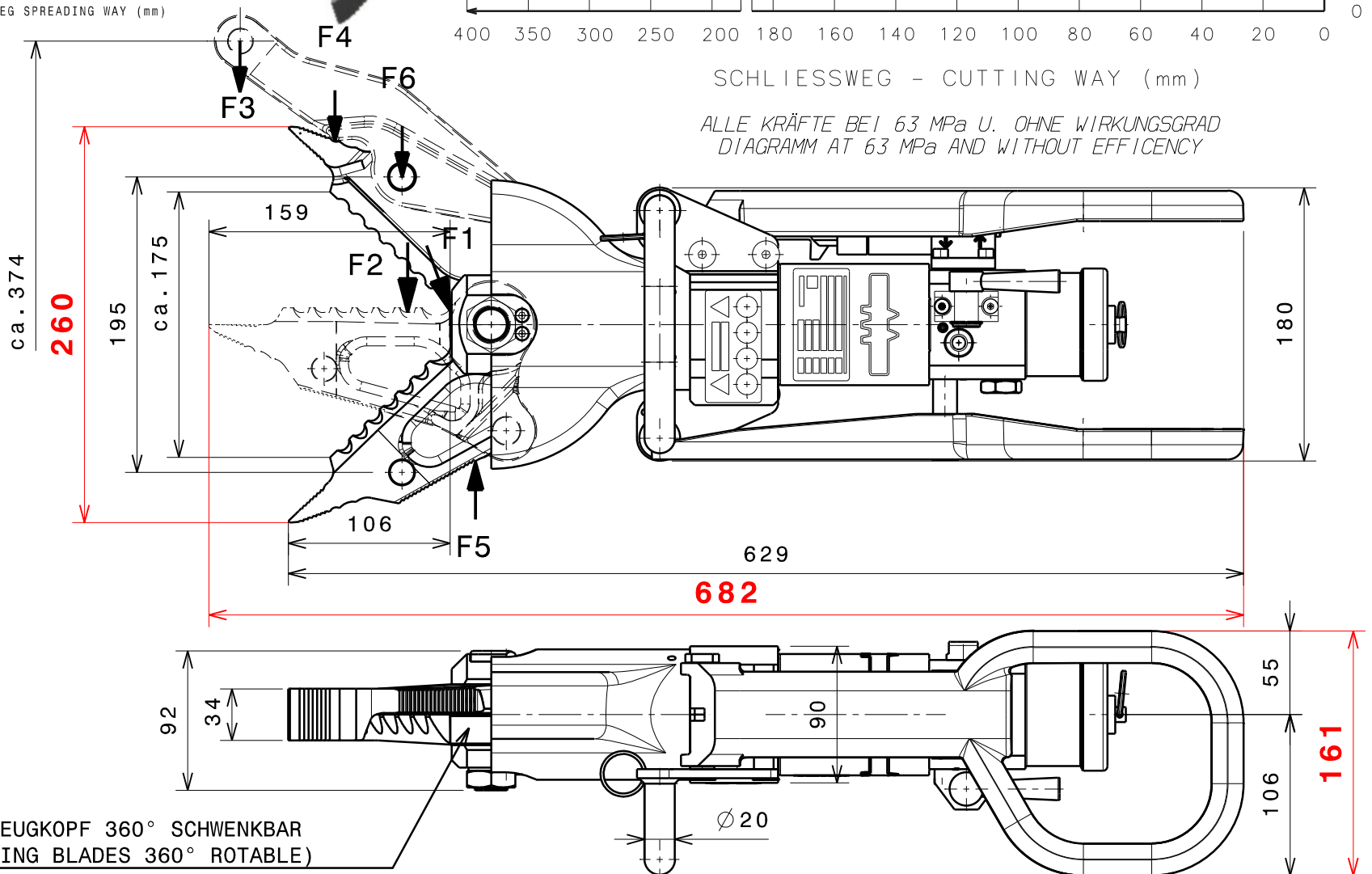

GEPR. JSC
GEZ. KST
KST
GEAEND. MODIF.
AEND.-DATUM
MOD.-DATE
AEND.-NR. 120405
REVISION D

DAT. 14.02.07

DAT. 11.06.12

FREIMASSTOLERANZEN (GENERAL TOLERANCES)	LAENGENMASS (LENGHT)mm	...50	50...250	250...1000	1000...	WINKELMASS (ANGLE)	...180°
	TOLERANZ (TOLERANCE)mm	±1,5	± 2,0	± 3,0	± 5,0	TOLERANZ (TOLERANCE)	±10°