



# TECHNICAL DATA

## PILOT REGULATING FLOW CONTROL TRIM

4" (DN100) MODEL J  
FLOW CONTROL VALVE

The Viking Corporation, 210 N Industrial Park Drive, Hastings MI 49058  
 Telephone: 269-945-9501 Technical Services: 877-384-5464 Fax: 269-818-1680 Email: techsvcs@vikingcorp.com  
 Visit the Viking website for the latest edition of this technical data page: www.vikinggroupinc.com

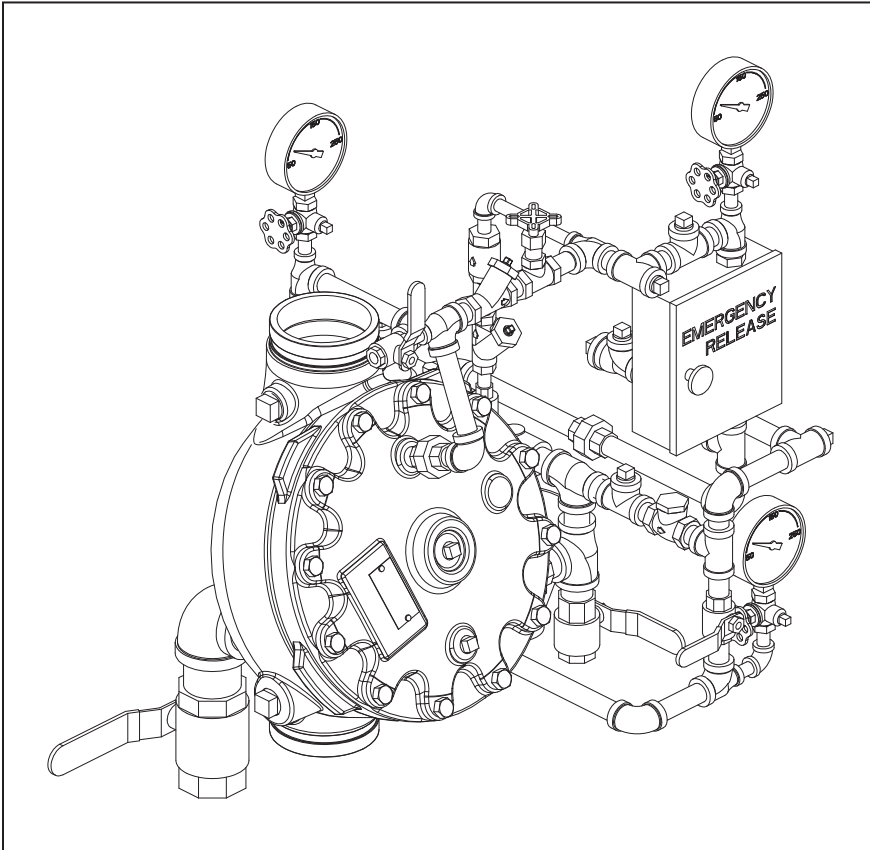

This Trim Chart is for use with the following Viking Trim Sets

Valve Size	Galvanized Trim Part No.	Brass Trim Part No.
4" (DN100)	14770-1	14770-2

This trim is for use with the following Release Module Trim Kits

Release Type	Galvanized	Brass
Electric	<a href="#">10830</a>	<a href="#">10832</a>

**Note:** Nipple lengths for brass trim may vary from those shown on this Trim Chart.

Note: When viewing this data page online, [blue](#) text represents hyper links and will open the appropriate data page when clicked.

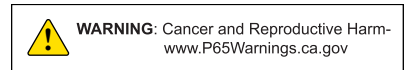

### Notes: For use with Trim Charts on Page 2

#### General Notes:

- Valve must be trimmed as shown. Any deviation from trim size or arrangement may affect the proper operation of the valve.
- Dimensions in parenthesis are millimeters.
- Viking uses ANSI tee designations (large outlet on run, small outlet on run, side outlet) in all trim call-outs.

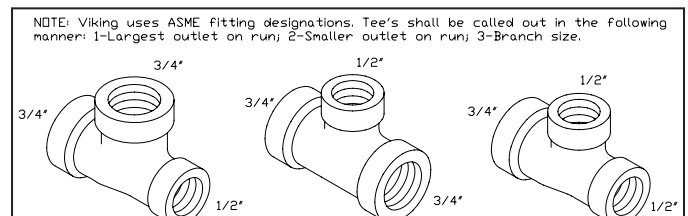

**Note 1:** Release System connection.

**Note 2:** Alarm Connections: Connect alarm line piping to 3/4" (20 mm) NPT outlet. When using a Water Motor Alarm, a strainer is required. 1/2" (15 mm) NPT outlet is for electric Alarm Pressure Switch.

**Note 3:** Optional non-interruptible connection for Alarm Pressure Switch to activate electric alarm panel. Note: After the Deluge Valve trips, this location cannot be shut off. Alarms may operate until the outlet chamber of the deluge valve is de-pressurized below the set point of the Alarm Pressure Switch.

**Note 4:** Viking Drain Check Valve is manufactured with a 0.067" (1.7 mm) orifice to allow alarm line to drain. Do not substitute. Check label for proper orientation.



# TECHNICAL DATA

## PILOT REGULATING FLOW CONTROL TRIM 4" (DN100) MODEL J FLOW CONTROL VALVE

The Viking Corporation, 210 N Industrial Park Drive, Hastings MI 49058

Telephone: 269-945-9501 Technical Services: 877-384-5464 Fax: 269-818-1680 Email: techsvcs@vikingcorp.com  
Visit the Viking website for the latest edition of this technical data page: www.vikinggroupinc.com

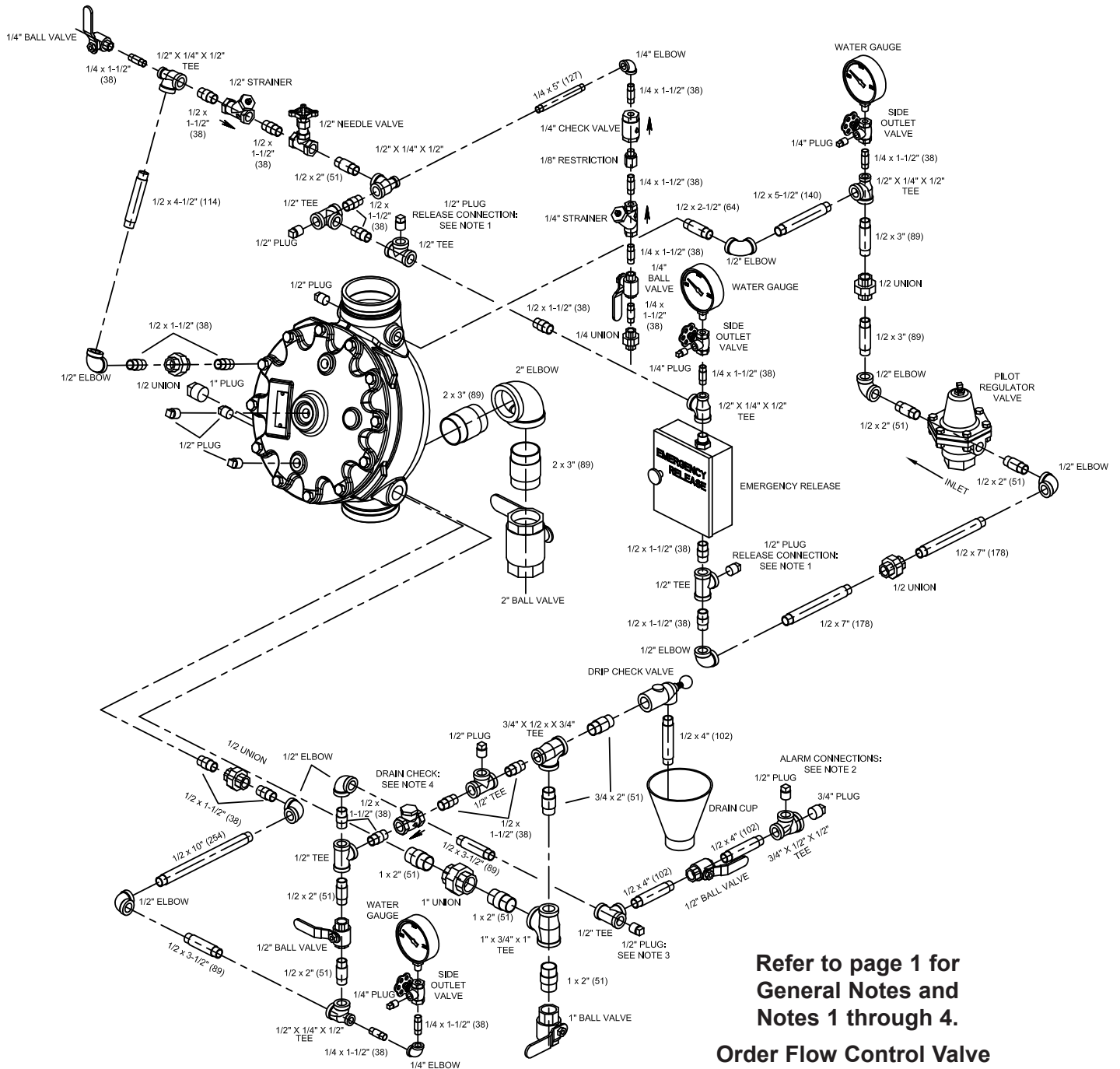

Refer to page 1 for  
General Notes and  
Notes 1 through 4.  
Order Flow Control Valve  
Separately

**Figure 1**  
**4" Pilot Regulating Trim for Model J Flow Control Valve**

**VIKING<sup>®</sup>****TECHNICAL DATA****PILOT REGULATING  
FLOW CONTROL TRIM**4" (DN100) MODEL J  
FLOW CONTROL VALVE

The Viking Corporation, 210 N Industrial Park Drive, Hastings MI 49058  
 Telephone: 269-945-9501 Technical Services: 877-384-5464 Fax: 269-818-1680 Email: techsvcs@vikingcorp.com  
 Visit the Viking website for the latest edition of this technical data page: www.vikinggroupinc.com

