

DATA SHEET #NDD160

PC-150 & PC-200 MONITOR MOUNTED NOZZLES

Description

The PC-150 and PC-200 Air Aspirating Foam Nozzles are designed to be mounted on fixed or portable monitors and can be used anywhere high capacity foam streams are required. The air aspirating design produces superior foam with all foam types, resulting in increased expansion and longer drainage times than with non-air aspirating type nozzles. This results in premium foam blanket performance and stability for safer operation. Nozzle discharge pattern is adjustable from full spray to straight stream allowing the operator precise control of the foam application. The nozzle is available in flow rates of 1500 or 2000 gpm @ 150 psi inlet pressure (5678 or 7571 lpm @ 10.3 bar).

Features

- High capacity, air aspirating, monitor mounted foam nozzle.
- Excellent foam production with protein, fluoroprotein, AFFF, and AR-AFFF type foams.
- Brass and stainless steel construction for superior corrosion resistance and wear.
- Fully adjustable pattern from straight stream to full spray.
- Superior nozzle reach allows safe placement remote from the hazard.
- Suitable for operating pressures from 50 to 200 psi (3.5 to 13.8 bar).

Applications

The PC-150 and PC-200 Air Aspirating Foam Nozzles can be mounted on manual, oscillating, and remote controlled monitors. They are commonly used to protect product storage tanks, dikes, process areas, and loading racks. The nozzles are suitable for use on foam pumpers, foam trailers, aerial apparatus, and various marine applications such as tankers and barges, chemical carriers, fire boats, docks, and offshore platforms.

Specifications

The PC type nozzle shall be a monitor mounted air aspirated design for use with all types of foam concentrates. The air-aspirating design shall produce superior foam, with all foam types, resulting in increased expansion and longer drainage times than can be achieved with non-air aspirating nozzles. A pattern control assembly shall be provided to allow selection of nozzle discharge from full spray to straight stream. The nozzle can be supplied with flow rate choices of 1500 or 2000 gpm @ 150 psi inlet pressure (5678 or 7571 lpm @ 10.3 bar) and shall be suitable for use with all foam concentrates.

The nozzle shall be available with a cast brass foam maker and stainless steel discharge tube. The orifice shall be a shaped jet to improve the efficiency of the nozzle. The orifice shall be removable and held in place with a snap ring. The nozzle shall have a 5" flanged inlet.

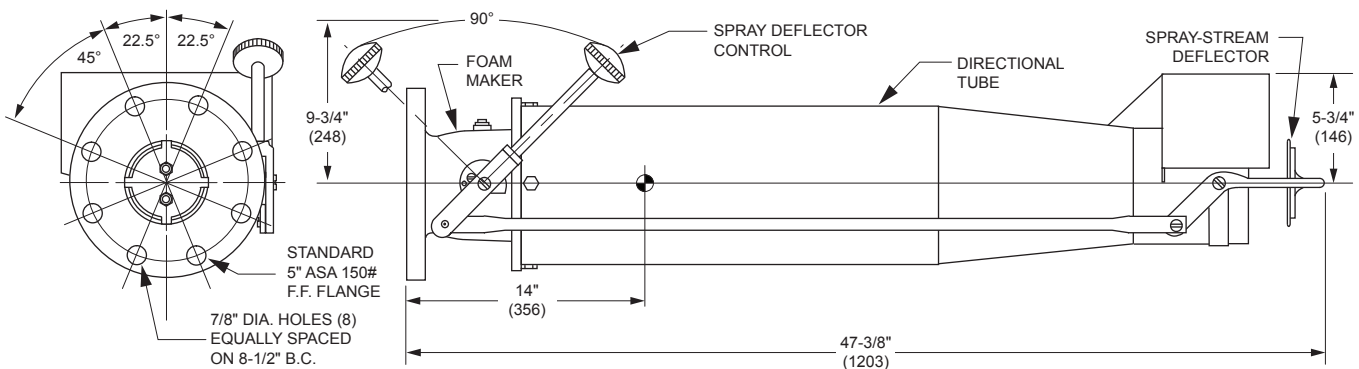

Approvals

- UL Listed
- FM Approved
- USCG Approved

Technical Data

Materials of Construction:

Foam Maker Cast Brass, ASTM B-62
 Discharge tube Stainless Steel
 Deflector Cast Brass
 Deflector Rod Stainless Steel Tubing
 Swivel Gasket Buna- N

Finish: Abrasive Blast to SSPC-SP6.
 Chemical wash, rinse, and seal. Oven baked fusion coated polyester, 3 mils dry film thickness (DFT), gold color

Working Pressure: 150 psi (10.3 bar)

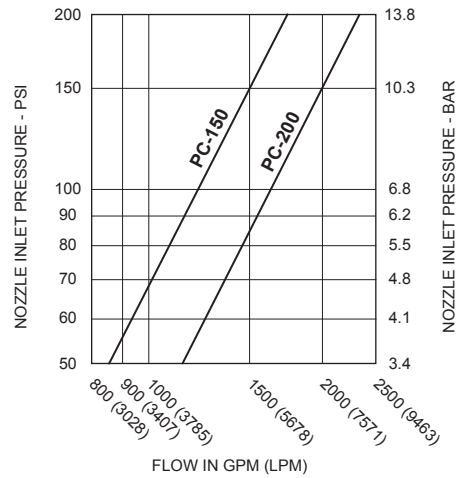

WATER OR FOAM SOLUTION NOZZLE DISCHARGE CHARACTERISTICS

Options

Hydraulic Spray Actuator

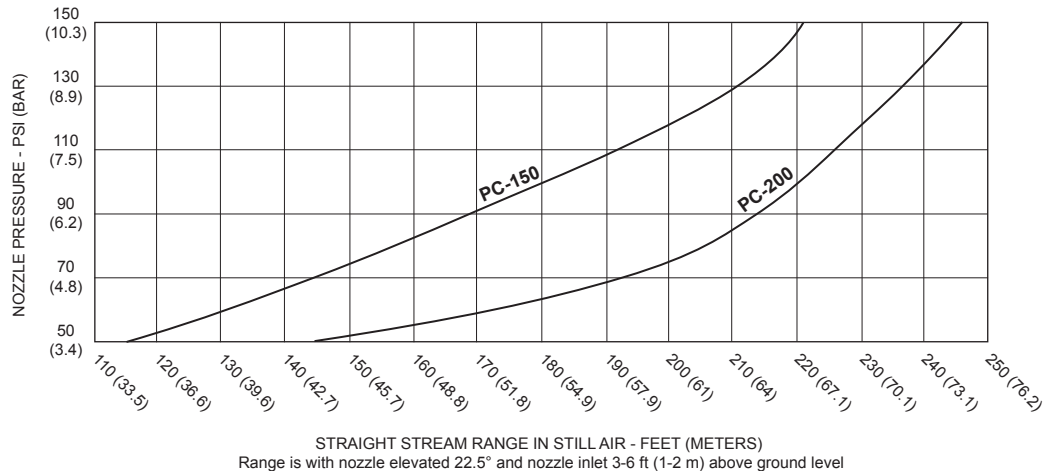

STRAIGHT STREAM RANGE IN STILL AIR - FEET (METERS)
 Range is with nozzle elevated 22.5° and nozzle inlet 3-6 ft (1-2 m) above ground level

RANGE CHARACTERISTICS OF STRAIGHT STREAM NOZZLES

Ordering Information

Part Number	Model	Actuator	Flow @ 150 psi (10.3 bar)	Material	Weight
1251-1612-3	PC-150-MOS	Manual	1500 gpm (5678 lpm)	Brass & SS	75 lb (34 kg)
1251-1612-4	PC-150-HOS	Hydraulic	1500 gpm (5678 lpm)	Brass & SS	88 lb (40 kg)
1251-1515-1	PC-200-MOS	Manual	2000 gpm (7571 lpm)	Brass & SS	75 lb (34 kg)

This information is only a general guideline, and each installation may require modifications to meet the applications or requirements of that situation. The company reserves the right to change any portion of this information without notice. Terms and conditions of sale apply and are available on request.

06/13 (Rev. C) Printed in U.S.A. (NDD160.INDD)

NATIONAL FOAM

P.O. Box 695 • Exton, PA 19341-0695 • (610) 363-1400 • Fax: (610) 524-9073

www.Kidde-Fire.com